



SILHOUET-TONE®

ESSENTIAL

Peel

INSTRUCTIONS
MANUAL



www.silhouettone.com

Content

Essential Peel

01. Important Safeguards	3
02. Control panel	4
2.1 Connecting the handpiece	5
2.2 Disposable tips	6
2.3 Corundum Crystals	6
2.4 Unit Preparation before Microdermabrasion	7
2.5 Filters Replacement	7
03. Contraindications	9
04. Client Record Card	10
05. Microdermabrasion Protocol	11
5.1 Microdermabrasion Schedule	11
5.2 Preparation for microdermabrasion	11
5.3 Suggested Settings	12
5.4 Microdermabrasion Techniques	13
5.5 Microdermabrasion Procedure Chart	14
5.6 Microdermabrasion Procedure (20-40 min)	15
06. Combining Microdermabrasion with Facial Procedures	17
07. Other Applications of Microdermabrasion	18
08. Client Instructions Sheet	19
09. Essential Peel Consent Form	20
10. Important	21
11. Specifications	22

ESSENTIAL

The logo for 'Essential Peel' features the word 'ESSENTIAL' in a bold, sans-serif font. The letter 'A' is stylized with a double-headed arrow pointing left and right. Below 'ESSENTIAL' is a thin, curved line that arches over the word 'Peel', which is written in a smaller, lowercase, sans-serif font.

Peel

Thank you for purchasing the Essential Peel microdermabrasion system. We realize that there are many microdermabrasion systems available and we are confident that choosing a Silhouet-Tone product, crafted and manufactured in North America, will reward you with many years of trouble free operation and the excellent results the industry has come to expect from Silhouet-Tone products.

All rights reserved. No part of this work covered by the copyright hereon may be reproduced or used in any form or by any means—graphic, electronic, or mechanical, including photocopying, recording, taping, or information storage and retrieval systems—without permission of the company.

© 2014

01. Important Safeguards

Read the following instructions before using this apparatus!

1. This apparatus is to be used only for purposes that are approved and described in the following manual. Use only with attachments recommended by the manufacturer.
2. Never perform a procedure on inappropriate or sensitive areas.
3. Prior to each use of the system, inspect all cables and attachments for any damage, excessive wear, or crimping that could affect system performance or safe operation. Never use the system if any damage is visible.
4. Do not use this apparatus if the power cord has been damaged, if it is not working / operating correctly or damaged. Return apparatus to service center for verification or repair.
5. Keep power cord away from heat source.
6. **WARNING:** To avoid the risk of electric shock, this equipment must only be connected to a supply main with protective earth.
7. **WARNING:** Caution should be exercised to avoid spilling any liquids on the unit.
8. Never pull the power cord to disconnect the equipment from the mains. Always do so by firmly grasping and pulling the connector. Always allow enough space between the equipment and the mains for easy disconnect or plug in access.
9. This apparatus should only be operated by an appropriately trained and certified personnel possessing knowledge of the skin physiology and only in a professional setting. If you have any questions regarding the operation of this unit, contact Silhouet-Tone or your local distributor.
10. Grounding instructions:
This unit must be properly grounded. In the event of a short-circuit, the power cord's ground prong will reduce the risk of electric shock by providing an escape route for the current.
The power cord is equipped with a grounding wire and three-pronged plug. The power cord must be plugged into a properly installed three-pronged grounded outlet.
DANGER: THE IMPROPER USE OF A GROUNDING PLUG MAY CAUSE ELECTRIC SHOCK.
11. The power cord should be routed so that they are less likely to be walked on or pinched by items placed on or against them. Pay particular attention to cords at plugs, convenience receptacles, and the point where they exit the unit.
12. Do not use any adaptors with this unit. Do not modify the plug if it does not fit the outlet. Have an electrician install a suitable outlet.
13. Do not overload wall outlets and extension cord; this can lead to an increase risk of fire or electric shock.
14. All maintenance work must be done by SILHOUET-TONE or an authorized service representative. Do not attempt to service this unit yourself. Opening the unit may expose you to high voltage or other hazards, and will void your warranty. Always use Silhouet-Tone certified replacement parts and accessories.
15. To insure continuous protection against fire, always replace the fuse with one of identical type and amperage, as approved by the manufacturer.
16. Never immerse the hand piece in any type of solution.
17. Slots and openings in the unit casing are for ventilation. They are there to ensure reliable operation and prevent overheating. These openings must not be blocked or covered. This unit should not be placed in a built-in installation unless proper ventilation is provided for.
18. Do not use corundum crystals other than those recommended by the manufacturer. Improper granulometry can damage the unit's components and create blockages.
19. Do not use the unit near water—for example: near a sink, wash bowl, hydro tub, steamer, wet table, swimming pool, autoclave, hot cabi.

Save these instructions!

02. Control Panel

Front view

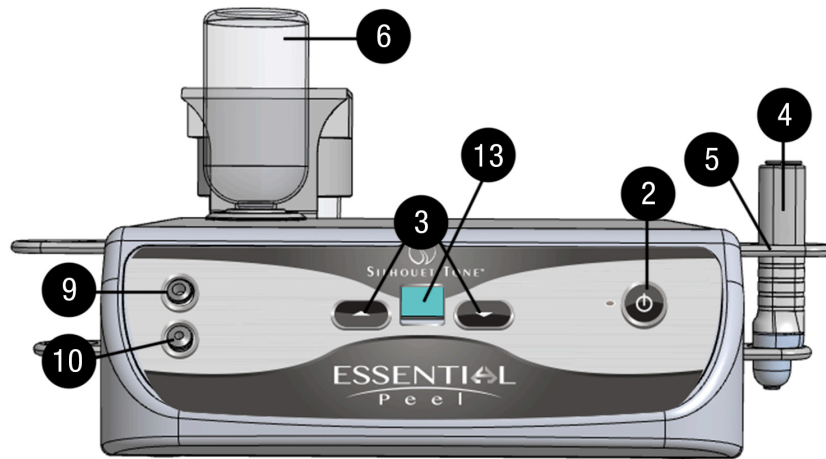

Back view

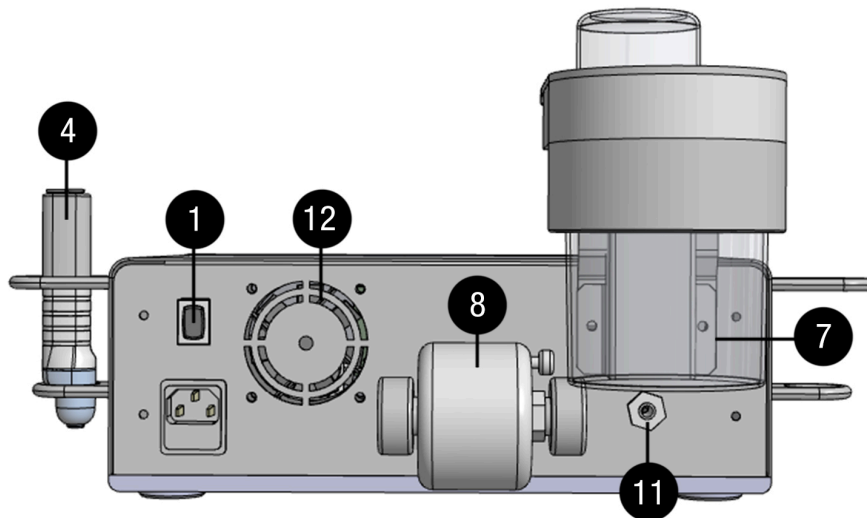

- | | |
|---|---|
| 1. Main power switch (located at the back of the unit). | 8. Security filter. |
| 2. START / STOP session key. | 9. Narrow hose (front panel connector). |
| 3. Intensity control. | 10. Large hose (front panel connector). |
| 4. Handpiece. | 11. Air inlet orifice. |
| 5. Handpiece cradle. | 12. Ventilation opening. |
| 6. Clean crystal outlet. | 13. Intensity display screen |
| 7. Container for used crystals. | |

Turning the unit ON

Important to respect the following sequence:

1. Connect the power cord to the back panel of the unit. Plug it into the wall (the wall plug will only fit a three prong grounded power outlet).
2. Connect the handpiece (as per instructions below).
3. Install empty crystal container in place (used crystals #7) (as per instructions below).
4. Install new crystal container in place (#6) (as per instructions below).
5. Turn on the main power switch on the back of the unit (#1). *The LED indicator on front panel will light up.*
6. Wait at least 10 seconds for unit to warm up.
7. Press the "START / STOP" key (#2 on the front panel).
8. Adjust the abrasion/vacuum power with the intensity key (#3 on the front panel).
9. The intensity will appear on your screen (#13).

2.1 Connecting the Handpiece

WARNING:

- ✓ **IMPROPER TUBE CONNECTION WILL BLOCK THE UNIT!**
- ✓ **NEVER connect the handpiece while the unit is ON.**

Connecting the handpiece | Connecting the plastic tubes

- The narrow hose connects to the front panel's small connector and to the handpiece's small connector.
- The larger hose connects to the front panel's large connector and to the handpiece's large connector.

NOTE: Narrow hose = clean crystals; Larger hose = used crystals. Both hoses must be inserted at least 1 cm (1/2 inch) into their respective connectors.

- Place the handpiece in its support (cradle).

Handpiece

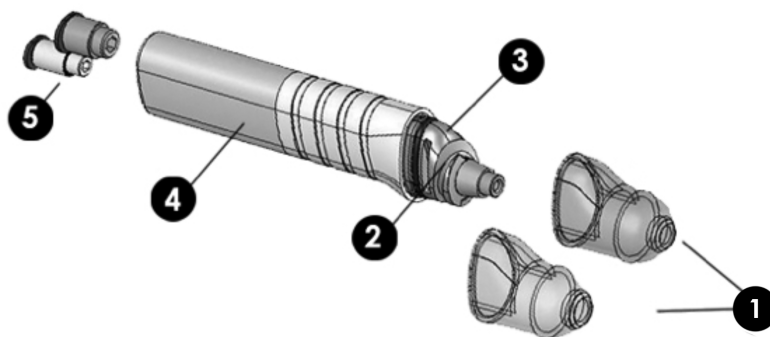

1. Disposable plastic tips.
2. O-Ring.
3. Spiral head.
4. Handpiece body.
5. Quick connect fitting.

2.2 Disposable Tips

For safe, efficient and hygienic applications, the unit comes with disposable plastic tips. Two sizes are available:

- **Blue tip:** Gentle abrasion, ideal for fine skin and sensitive areas.
- **Green tip:** Stronger abrasion, ideal for thicker skin and non-sensitive areas.



IMPORTANT: It is very important to clean the handpiece with a dry paper tissue to remove loose crystals before inserting a new disposable tip.

- Choose the appropriate disposable plastic tip. Place on the handpiece so that it fits tightly.
- Before using a plastic tip, make sure that it is in good condition, neither cracked nor damaged, and that it has no sharp edges that could cause injury. The tip may be reused up to 5 times on the same client.
- Keep tip with client file. Do not give the tip to client. Disinfect the used tip with alcohol, making sure it is perfectly dry before proceeding with the microdermabrasion session.



IMPORTANT: Using a damaged tip will result in weak suction. If suction is weak, check the tip and replace, if necessary.

2.3 Corundum Crystals

- Corundum is a natural mineral with excellent abrasive qualities.
- Corundum crystals are Al_2O_3 (aluminum oxide) pure at 99.24 % and highly uniform granulometry 120 μ (microns).
- It is not recommended to use crystals other than those supplied with the equipment. They may be harmful to your clients and will damage your equipment.



WARNING: To avoid cross contamination, never use crystals more than once. Used crystals have lost their abrasive properties and are contaminated.

How to replace the “clean crystal” bottle

- ONLY WHEN EMPTY, proceed to remove the clean crystal bottle. If there are too many crystals left in the receptacle, use the vacuum hose to remove the before placing the new bottle in. Disconnect the large hose from the handpiece and use it to vacuum the excess crystals.
- Turn on the unit on to maximum intensity, and use the vacuum hose to clean all crystal residues from the clean crystal outlet. Turn the unit OFF.
- Remove the new "clean crystal" bottle cap (**DO NOT REMOVE PROTECTIVE SEAL**); screw it in place.
- If something is trapped in the small hose, there will be no crystal projection. If this happens:
 - Run the unit at full power (10) for 10 seconds while blocking both the hand piece opening and the air hole (air inlet orifice # 11), located at the back of the unit. Repeat this procedure 3 times. If there still is no crystal projection, repeat again at maximum intensity.
 - This procedure will remove all crystals and debris trapped in the hoses and prevent blockage.



IMPORTANT:

- ✓ When using a “new crystal” bottle, always empty or replace the “used crystal” container.
- ✓ At the end of each procedure, use alcohol wipes to remove excess crystals from the hand piece.

2.4 Unit Preparation before Microdermabrasion

Before each session, you **MUST** check the following:

- The clean crystal bottle is tightly in place.
- The "used crystal" container has been emptied or replaced.
- Before putting container in place, remove any crystal residue from the ridges with a dry tissue and make sure that the container is properly closed.



WARNING: For sanitary reasons and for the safety of your unit, corundum crystals must never be reused.

Starting procedure session

1. Turn on the main power switch on the back of the unit (#1). *The LED indicator on front panel will light up.*
2. Wait at least 10 seconds for unit to warm up.
3. Press the "START / STOP" key (#2 on the front panel).
4. Adjust the abrasion/vacuum power with the intensity key (#3 on the front panel).
5. The intensity will appear on your screen (#13).
6. Start exfoliation procedure.

2.5 Filters Replacement

The Essential Peel unit has 2 filters which **require periodic replacement**. Skin debris vacuumed into the "used crystal" container reduces efficiency. When suction diminishes, it is time to change the filter*.

NOTE: The filters will require less maintenance if the client's skin is perfectly cleaned and dried prior to each session. We recommend the use of a water based cleansing lotion to avoid clogging problems. The skin must be completely free of any moisture; use a hair dryer to complete the drying process. Any moisture left on the skin will create hose or filter clogging.

How to change the small "used crystal" filter (ST Code 416597):

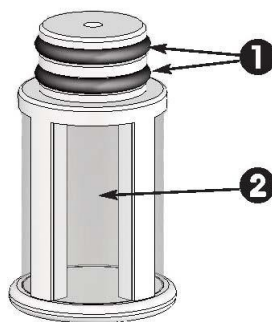
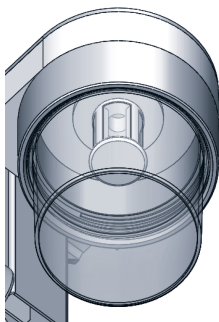

Small "used crystal" filter

1. Rubber ring
2. Plastic mesh (filter)

Procedure:

- This small filter is good for approximately 40-50 procedures.
- When the filter needs to be replaced, "CF" inscription will appear on the display screen (# 13 on the front panel).
- Unscrew the used crystal jar.
- Pull out the used filter and discard it.
- Holding the new filter by the white plastic base, push it in with a light twist.
- Press concomitantly on both intensity control arrows (# 3 on the front panel) to reset the "CF" inscription.
- You can restart a new series of about 40-50 sessions.

! ATTENTION:

- ✓ Be careful not to damage the filter's plastic mesh when pull it out.
- ✓ Make sure that the two seals (rubber O rings # 1) are on the filter and that the plastic mesh (# 2) is not perforated.

How to change the external, large safety filter (ST Code 416613):

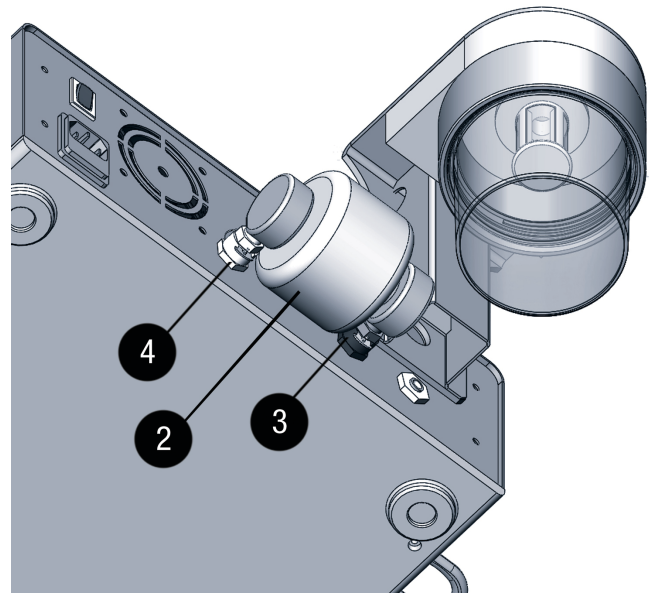
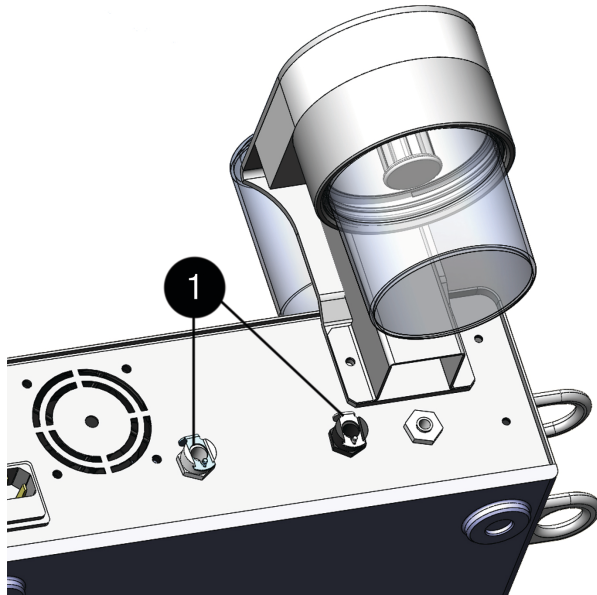

- 1. Metallic Tabs
- 2. Filter

- 3. Black connector
- 4. White connector

! IMPORTANT

- The external safety filter, located on the back panel, will need changing yearly, depending on usage. The main external filter protects your motor against fine particles which can reduce the efficiency or damage your unit.
- It is important to only use corundum crystals recommended by Silhouet-Tone. **Using Silhouet-Tone corundum crystals will prolong the life of your filters and ensure the proper operation of your unit.**
- The external safety filter is good for 1 (one) year, it is always prudent to keep an extra filter in stock.
- Filter should be changed when projection intensity drastically decreases and filter lines are no longer visible (*This indicates the filter is filled up with crystal particles and skin debris*).

Procedure:

- Press on the two metallic tabs (#1) and pull the filter out of the connectors.
- Replace the large safety filter (#2)
- Match the white and black filter (#3, #4) connectors to the Essential Peel connectors.
- Push the filter assembly into position (*you should hear two clicks*).

03. Contraindications

Reminder

- The “Essential Peel” is a microdermabrasion unit used to perform surface skin exfoliation and makes no medical claims. It is intended and should be used by licensed estheticians for esthetic purposes only.
- Refer all medical problems to a physician.
- All procedures must be performed on healthy skin, free of infectious or inflammatory conditions.
- Do not abrade beauty spots, moles or (naevocellular naevi). Bypass them without touching them.

CONTRAINDICATIONS:

- People allergic to aluminum oxide (Al_2O_3).
- People with active or uncontrolled diabetes;
- Skin cancer, autoimmune disease or anti;
- Active local skin infection of all types (herpes simplex virus, flat warts, eczema, dermatitis etc.).
- Active acne (with pustules).
- Vascular lesions (broken capillaries and rosacea).
- Severe rosacea or telangiectasias.
- On pigmented solar keratosis, sunburned areas or recently laser or IPL treated areas;
- Users of prescription anticoagulants (blood thinners as Cumaden or Warfarin) or corticoids (cortisone or prednisone).
- Any medical condition that prohibits exfoliation.



WARNING:

- ✓ **BEFORE A PROCEDURE, INSPECT THE TIP for any excessively jagged or abnormally formed surfaces on the tip (anything that could cause a cut in the skin). DO NOT USE THE TIP if you notice any damage.**
- ✓ **Prior to procedure, always test the abrasion intensity on the inside of the client’s forearm, where the skin is most sensitive. Wait for 5 minutes and if no reaction is observed (redness, rash, bumps, swelling or any other reaction on tested area) you can begin procedure. If any reaction appears, do not proceed, if necessary refer the client to a doctor.**
- ✓ **Extra care must be taken when working on mature or reactive skin.**
- ✓ **For first exfoliation, always use the lowest suction.**



Important recommendations:

- **Prior to microdermabrasion**, client must discontinue use of any any irritating products (such as retinoids (Retin A) or AHA’s (glycolic or lactic acid) for one week. Use may resume 3 weeks following microdermabrasion interruption.
- Never use products Retin A or AHA’s (*such as glycolic*) or other chemical peels or low pH products in conjunction with microdermabrasion sessions.
- Avoid microdermabrasion before intense sun exposure (ex. sailing, skiing, sun bathing).
- Clients should avoid swimming in a chlorinated pool **the day of the microdermabrasion**.
- It is recommended that clients wait 4-6 weeks after receiving Botox and filler injections.
- Users of Isotretinoin medication (Accutane, Roaccutane) must wait 6 months between medication interruption and beginning of exfoliation procedure.
- **3 months prior to microdermabrasion, discontinue any laser or IPL treatments.**

04. Client Record Card

We recommend that you keep a client record card on which you note the client's medical history and medications. Some medications cause hyperpigmentation and will cancel out the effects of microdermabrasion.

It is important to note the following:

- Quality of skin: firm, soft, distended, fine, thick, etc.
- Skin sensitivity: normal, reactive, hyper-reactive, intolerant to...etc.
- Pigmentation problems: solar keratoses, birthmarks, acne, melasma, etc.
- Skin problems: acne, rosacea, sebaceous cysts, wrinkles, enlarged pores, loss of elasticity, vascular problems. When noting wrinkles, specify: superficial or deep.
- Scars or stretch marks; note the cause, date of occurrence, size, and depth.
- Other procedures currently being used by the client, such as chemical peels, IPL, laser, RF etc.
- Skincare products presently used by the client.
- Skin reaction to each microdermabrasion session should be noted on the client card.

05. Microdermabrasion Protocol

5.1 Microdermabrasion Schedule

The Essential Peel microdermabrasion system is used to perform surface skin exfoliation. Informing the client and setting reasonable expectations is essential to prevent disappointment, especially with problem skin. It may take multiple abrasion procedures before seeing improvements and clients should be made aware.

Microdermabrasion sessions should be scheduled at 8 to 15 day intervals, depending on client's skin type:

- Oily and thick skin: 8 days;
- Normal skin: 10 days;
- Dry, dehydrated or sensitive skin: 15 days.

A series consists of 6 to 12 microdermabrasion sessions.

The number of sessions will be also determined by the client's age and problem severity (flaws, pigmentation, etc.).

After 6 sessions, results should be evaluated and a second series may be suggested.

One procedure per month is recommended to maintain results.



IMPORTANT Recommendations Prior to Microdermabrasion

- ✓ 1 week prior to microdermabrasion, client must discontinue use of Retin A, AHA's or (glycolic acid) or other chemical peels.
- ✓ 3 months prior to microdermabrasion, discontinue any laser or IPL treatments as well as chemical peels.
- ✓ Clients taking oral prescription medication for acne treatments (isotretinoids such as Accutane) should wait 6 months after the end of their acne treatment before undergoing microdermabrasion.
- ✓ Postpone microdermabrasion if a client has planned intense sun exposure: sailing, skiing, etc.
- ✓ Postpone microdermabrasion in case of dermatitis; infectious acne, eczema, psoriasis, active herpes (cold sore).
- ✓ Postpone if skin is irritated or sun burned.

5.2 Preparation for microdermabrasion

Certain conditions are recommended for optimum microdermabrasion:

- The aesthetic bed or chair should be at the right height (hydraulic or electric bed). You must place yourself in a position so the hand piece can touch the client's face effortlessly and without pressure.
- The use of a 5 diopter magnifying lamp will allow you to accurately control the level of the microdermabrasion procedure and will prevent excessive exfoliation.

The following products must be within reach:

- water based cleansing gel;
- hydrating and/or soothing ampoules (vials);

- hydrating and/or soothing cream;
- hydrating and/or soothing mask;
- sunscreen with SPF 15 to 30;
- vinyl gloves (some clients are allergic to latex gloves);
- surgical mask
- adhesive protective eye shields or small gauzes to place under plastic goggles;
- Large gauze to remove crystal residue.

General recommendations:

- It is necessary to protect the client's eyes with self-adhesive eye shields or dry gauze pads covered with protective goggles, and secured with elastic around the head.
- Always work on dry (moisture free) skin.
- We recommend the use of a hair dryer, set to a low temperature to dry the skin prior to microdermabrasion.
- We recommend the use of protective mask and vinyl surgical gloves while working.
- The crystal projection is activated only when an occlusion is created by applying the handpiece on the skin.
- For comfortable and efficient procedures, always pull the skin taut between thumb and fore- finger.
- Never apply pressure with the handpiece; the vacuum pressure does the work.

Preparing the skin for microdermabrasion:



Contact lenses must be removed prior to procedure.

Skin cleansing

- Cleanse the skin with a water based cleansing lotion or gel.
- Rinse thoroughly with water. The use of toner is not necessary.
- Dry skin thoroughly.
- Remove headband since it will be wet following skin cleansing.
- First, dry skin using tissue paper, then with a hair dryer at a low setting, to insure face surface is **completely** dry.

Client preparation

- Use a clean dry headband or bonnet to cover client's ears.
- Protect client's eyes with self-adhesive shields or gauze pads covered with plastic goggles.



IMPORTANT:

Because crystals are highly susceptible to moisture, it is extremely important that the face be thoroughly dry to avoid vacuuming any moisture into the tubes, which can result in clumping of the crystals and blockage of the tubes.

5.3 Suggested Settings

A successful microdermabrasion procedure begins by selecting the appropriate tip, number of passes, and vacuum setting.

The depth of exfoliation depends on the intensity of the suction and number of passes.

Power settings vary between from 1 and 10. The digital display allows for 10 levels of intensity.

Intensity Settings:

10 intensity levels, using 1 unit increments:

When using **blue** disposable tip:

Intensity **1 to 6** is generally used for:

- New client, first session
- Dry, sensitive skin with redness or reactive skin
- Fragile areas such as the eye contour and neck

Intensity **6 to 10** is generally used for:

- Forehead, nose, cheeks, jaw line.

When using **Green** disposable tip:

Intensity **1 to 8** is generally used for:

- Combination skin with oily tendency
- Non sensitive areas.

Intensity **6 to 10** is generally used for:

- Enlarged pores, thicker skin or body areas

Upon contact with the skin (occlusion), a small amount of crystals is propelled, providing a slight abrasion. For a stronger abrasion, increase the intensity, taking the client's level of sensitivity and skin type into consideration.



CAUTION:

To ensure safe procedures, always test the intensity level on the inner portion of the client's forearm before proceeding to the face.

5.4 Microdermabrasion Techniques



IMPORTANT: To prevent your unit from clogging it is very important to work on skin which is completely dry!

3 basic techniques are used during microdermabrasion, the linear sweep, circular sweep and square pattern sweep:

- The linear sweep.
Used at the beginning of each session to exfoliate the epidermis. It is also used in a back and forth movement to improve the appearance of minor imperfections. When used at the end of each session the linear sweep will even out the exfoliation over the entire face.
- The circular sweep is used to improve the appearance of pigmented spots.
- The square pattern sweep is used to cover larger areas and improve the appearance of minor imperfections.

Between phases we recommend:

- Using soft gauze to remove crystal residue from the skin.
- Frequently reassessing the skin with the use of a magnifying lamp.

5.5 Microdermabrasion Procedure Chart

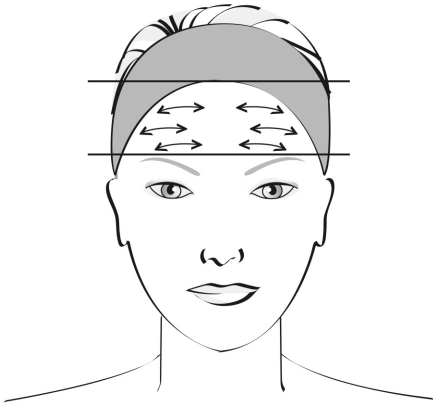

Phase 1

- Linear and “eraser like” sweeping”

After completing Phase 1, using dry gauze remove crystal residue from the skin and reassess the exfoliation with a magnifying lamp.

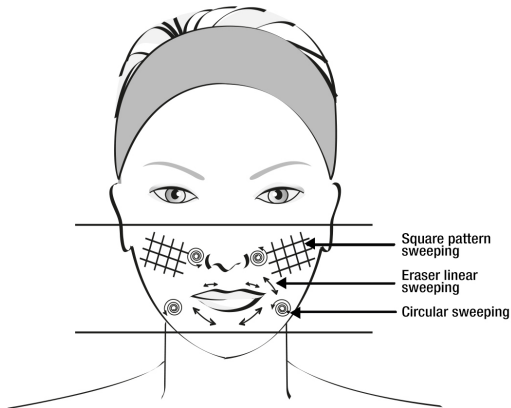

Phase 2

- “Eraser like” and square pattern sweeping.
- Circular sweeping will be used on pigmented spots.

After completing Phase 2, using dry gauze remove crystal residue from the skin and reassess the exfoliation with a magnifying lamp

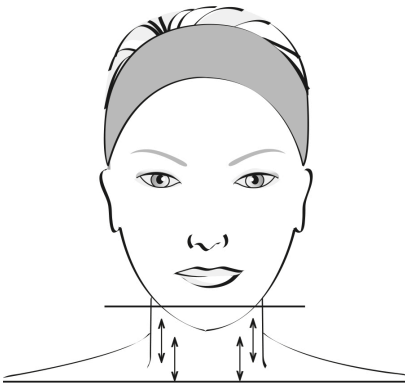

Phase 3

- “Eraser like” sweeping pattern.
Consists on rapid linear sweeps to even out skin tone.

Do not perform Phase 3 if the skin is red or irritated.

5.6 Microdermabrasion Procedure (20-40 min.)

Essential Peel microdermabrasion system is intended and should be used by licensed estheticians for esthetic purpose only.

The microdermabrasion procedure is divided into three basic phases:

Phase 1– general - involves the whole face. Use linear sweeps as per directions on the face chart. Consisting of one single pass and covering the entire face. Use rapid passes when working on sensitive skin

Phase 2- problem areas – Always use rapid passes when working on sensitive areas such as the cheek bone and under the eyes. Use “back and forth” linear passes when encountering wrinkles or scars. For pigmented spots, use a circular sweeping motion. To cover large areas with enlarged pores or uneven skin tone, use a square pattern, overlapping sweeps, as per directions on the face chart.

Phase 3- neck - Be cautious and work with lower intensities, the skin is thinner and more sensitive in this area. Always use single passes with a rapid motion. The skin must be pink never red.

Phase 3 is also used at the end of each session to even the exfoliation, if the skin is not red or irritated you can use linear sweeps over the entire face.

 **Important:** Between phases, it is important to remove excess crystals and reassess the skin using a magnifying lamp, Always use magnifying lamp to assess skin reaction.

Immediately after microdermabrasion:

- Remove crystal residues from the face.
- Apply a soothing cream and massage the skin. The cream will pick up remaining residues.
- Using wet gauzes, remove the cream, and rinse thoroughly with a soothing lotion.
- Apply a soothing moisturizing mask*, leave on for indicated time, remove.
- Spray on a soothing lotion and apply a protective cream with sunscreen.

Do not use a heat mask. We recommend the use of a cold modeling mask to reduce redness.

Important recommendations:

- ✓ Always test strength of exfoliation on client's forearm.
- ✓ Always begin with the forehead, working your way down to the chin and neck.
- ✓ Between phases always reassess the exfoliation. Skin should not be red but may have a pinkish tone.

Note: Client may feel a tingling sensation as products are being applied. Skin may feel heat sensation similar to light sunburn.

Session Duration

The duration of a session depends on the skin condition and the skin surface. The number of passes/sweeps will be higher on the body than on the face. The speed at which the sweeps are carried out also has an effect on intensity of exfoliation.

Session frequency

Each session produces specific results. Depending on the objective, a series of sessions, usually between 1 and 12 are suggested.

Maintenance

- 1 microdermabrasion per month will maintain results obtained from the series of sessions.
- 1 session per month will maintain a youthful appearance.
- 1 session prior to a special evening or occasion will provide an “instant glow”.

The client at home

- The client will see further improvement in the days following a procedure.
- To maximize results, the client should follow a healthy skin care regimen at home:
 - Drink 8 to 12 glasses of water per day.
 - Use hydrating products adapted to skin type.
 - Use a protective cream with sunscreen (SPF 15 to 30).
 - Stay out of the sun for one week following a microdermabrasion session.
 - To avoid irritation, all products applied after microdermabrasion must have a pH between 4.5 and 7.0.
- 48 hours after procedure:
 - Apply hydrating products regularly and as often as necessary.
 - A slight redness is to be expected, client may experience some desquamation during the third and fourth day.
 - Avoid saunas, swimming pools and whirlpools.
 - Avoid all sun exposure and tanning salons.
 - Always use sunscreen.
- One week after microdermabrasion procedure:
 - Avoid all sun exposure and tanning salons.
 - Continue using moisturizer and sunscreen.
 - Always use sun block when outdoor
- Three weeks after procedure:
 - Wait 3 weeks following a procedure before resuming use of Retin A, AHA's (glycolic acid), essential oils, or similar products (any chemical peelings or products containing these ingredients).

06. Combining Microdermabrasion with Facial Procedures

The Essential Peel is a microdermabrasion system used to perform skin exfoliation.

Microdermabrasion may be used to enhance the effects of other facial procedures. When used prior to applying professional aesthetic products it will accelerate results. When combined with microdermabrasion, cosmetic ingredients work at their full capacity.

NOTE: It is important to check the pH of cosmetic products. Low pH (acidic products) may cause an irritation. Products with a pH between 4.5 and 7.0 (with neutral pH) will be better tolerated.

Preparing the skin prior to a facial procedure:

- Cleanse the skin with an oil free cleanser.
- Dry the skin completely using hair dryer.
- Use microdermabrasion phase 1 and 2 only (*using lower intensity on sensitive skin*).
- Do not use steamers after microdermabrasion, heat may cause irritation
- Extract blackheads and comedones.
- Disinfect the skin.
- Apply cosmetic preparations (*must be pH balanced*).
- Perform a manual massage.
- Apply a hydrating or soothing mask.
- Apply soothing protective cream. Avoid using oil based or comedogenic products on oily skin, they might cause outbreaks.



WARNING:

Do not use chemical peels or any product containing AHAs (as glycolic acid), BHA (as salicylic acid), TCA (trichloroacetic acid), phenols, retinoids (as Retinol-A) or modified Jessner solutions (salicylic acid, lactic acid, resorcinol) in combination with microdermabrasion.

07 . Other Applications of Microdermabrasion

Hand Procedure (once a week)

Make sure hands are free of any oily substances and dry. Hand exfoliation can be added to manicure procedures, before the hand massage. Use a square pattern sweep all over the hands and circular sweeping on pigmented areas.

- Intensity 4 to 8 according to skin condition.
- To improve the appearance of pigmentation spots, use a skin lightener, immediately post abrasion procedure and for home care.

Décolleté Procedure (once a week)

- Intensity 6 to 10.
- The area must be clean and dry.
- Use a green disposable tip.
- Use a sweeping motion to cover the “Décolleté”.
- Use a back and forth sweeping pattern motion over the stretch marks until they become pinkish.
- Rinse and proceed with a massage using a firming cream.
- Apply a firming mask and moisturizer cream.
- Body Procedure Stretch Mark or scars (once a week)
- Intensity: 8 to 10, (according to skin sensitivity)
- The area must be clean and dry.
- Use a green disposable tip.
- Use a sweeping pattern to cover the area to be treated.
- Use a back and forth sweeping pattern on stretch marks until they become pinkish.
- Apply a stretch mark or firming cream.
- If desired, proceed with a body wrap (algae) or mud mask.



IMPORTANT:

The intensity levels are “suggested settings”. You must always consider the client’s level of sensitivity and skin type. Always do a “sensitivity test” to determine the suitable level of abrasion.

08. Client Instructions Sheet *(A copy must be given to client.)*

Prior to peel

- Discontinue use of: retinoid (Retin-A, Renova, AHA's etc.), glycolic or other acids at least one week prior to peel.
- Postpone procedure in case of active herpes (cold sore) outbreak or if you plan exposure to strong sunlight (such as sailing, skiing).

The client at home

- The client will see further improvement in the days following a procedure.
- To maximize results, the client should follow a healthy skin care regimen at home:
 - Your skin will feel like as though you have a mild wind burn or sunburn. Maintain hydration, both topically and internally. Drink 8 to 12 glasses of water per day. Use hydrating products adapted to skin type.
 - Use a protective cream with sunscreen (SPF 15 to 30). The use of a sunscreen above SPF35 is not recommended because of its high chemical concentration, which can provoke skin irritation.
 - Avoid sun exposure.
 - Avoid acid products Retin A, AHA's, (as glycolic acids) and chemical peels for three (3) weeks.
 - To avoid irritation, all products applied after microdermabrasion must have a pH between 4.5 and 7.0.
- 48 hours after procedure:
 - Apply hydrating products regularly and as often as necessary.
 - A slight redness is to be expected.
 - Avoid saunas and chlorinated swimming pools and whirlpools the day of procedure.
 - Avoid all sun exposure and tanning salons, as well as self-tanners.
 - Always use sunscreen.
- One week after microdermabrasion procedure:
 - Avoid all sun exposure or exposure to UV rays from the sun or tanning bed or self-tanner products.
 - Avoid waxing.
- Continue using moisturizer and sunscreen. Always use sun block when outdoor.
- Three weeks after procedure:
 - Wait 3 weeks following a procedure before resuming use of Retin A, AHA's (glycolic acid), essential oils, or similar products (any chemical peelings or products containing these ingredients).

Desquamation:

- During the 3rd and 4th day following the microdermabrasion, skin may peel.

Swelling and redness:

- Following procedure some skin types may show slight swelling, this is not a problem. Apply calming and hydrating products.
- Products containing Retin-A, AHA's (glycolic acid), enzymes or essential oils may also cause skin irritation when used after the procedure. Skin will therefore be over treated and may react causing swelling or redness.
- Reaction to a product will cause an intense heat sensation during product application. You must remove the product at once and use cool towel and a calming product.

09. Essential Peel Consent Form

Microdermabrasion is a widely used procedure performed by licensed estheticians, involving the exfoliation of the outer layers of the skin. This is accomplished by the projection of a natural mineral known as corundum crystals in a fine layer over the skin. The procedure is gentle and respects the integrity of the skin, with literally no recovery time for most people, though there are a few areas of the face where the procedure may feel slightly uncomfortable. Microdermabrasion has been successful in temporarily improving the appearance of small scars, large pores, pigmented spots, fine lines, wrinkles and comedones. This may take several sessions (average six) the number of which varies with each individual. _____

Because of the use of very small crystals, the ears and eyes must be covered during the procedure. It is recommended that contact lenses be removed prior to microdermabrasion. _____

The skin is cleansed before and after the procedure. Due to the unavoidable spread of crystals in the hair and possibly on the clothes, it is strongly recommended that the client shower before retiring that evening.

While these natural mineral crystals are not known allergen, the possibility of an irritation always exists due to the individuality of each client. _____

During cold sore, herpes simplex, inflammatory or acne eruptions, it is necessary to discontinue sessions to avoid spreading the condition. The procedure should be deferred until the skin is perfectly healed. _____

Because the skin, after microdermabrasion, has no natural protection, it is necessary to use neutral pH moisturizers and to wear a protective sunscreen no less than SPF 15 but no more than SPF 35. Failure to wear sunscreen can result in sunburn on your face, and skin damage could occur. _____

I do not present any of Contraindications:

(Yes) _____ (No) _____ (Check one)

If yes, Microdermabrasion procedures cannot be performed _____

While many satisfying results are achieved after six (6) session series, there is no guarantee that the desired effects will be achieved within that delay. Your own body response is a major factor in the result process. _____

I have read the preceding explanations and understand the potential risks and benefits of microdermabrasion. I received a copy of the "Client Instructions" sheet and agree to follow them and to protect my skin against the sun at all time.

Client Name : _____ Signature : _____

Telephone Number : _____ Date : _____

Witness Name: _____ Signature: _____

10. Important

This system makes no medical claims. This procedure is not used in any mean of treating any medical pathological condition. The system is intended and should be used by licensed estheticians for esthetic purposes only.

Terms microdermabrasion, abrasion, exfoliation or peeling terms describe the same procedure: the esthetic exfoliation.

The masculine generic refers to both the masculine and feminine genders and is used for conciseness purposes only.

If you have questions regarding the operation of this system, call Silhouet-Tone or your local distributor.

Silhouet-Tone is not responsible for damage or accidents caused by the incorrect or unprofessional usage of the system.

Accessories List		
416613	External Filter (large safety filter)	1
416622	Flexible Tubing (6/4)	1
22711562	O-Rings (for hand piece)	2
411485	Hand Piece	1
416643	Plastic protective goggles	3
421903	Instructions Manual	1
416533	Blue Disposable tips (package of 10 tips)	1
416613	Green disposable tips (package of 10 tips)	1
416010	Corundum crystal (453 gr./ 1lb)	
	Power cord (110V/230V)	1
	7A SB Fuses (110V/230V)	1

11 . Specifications

CSA Approved	
Universal Power Supply :	110 VAC - 240 VAC / 50 Hz - 60 Hz / 60 W
Fuse Type:	1A SB (110 VAC - 240 VAC)
Maximum Intermittent Vacuum Level:	- 0,8 bar
Sound Level at Maximum Free Flow:	65 dB - C Scale
Unit Dimensions:	Width: 17-1/2 in (445 mm) Height: 9 in (229 mm) Depth: 17-1/2 in (445 mm)
Unit Weight:	11.5 lbs (5.2 kg)
Construction:	Epoxy Coated Metal Housing Acrylic Accessory Tray Injection Molded Face Low Noise from Sound Damping Components
Electronics:	Accurate Microprocessor Controlled Drive System
External Filters:	Long-Life Replaceable Filters
Ambient Operating Temperature	+10° C to + 35° C
Ambient Operating Humidity:	30 % to 60 % RH

SILHOUET-TONE RESERVES THE RIGHT TO CHANGE THESE SPECIFICATIONS WITHOUT NOTICE.

All rights reserved. No part of this work covered by the copyright hereon may be reproduced or used in any form or by any means—graphic, electronic, or mechanical, including photocopying, recording, taping, or information storage and retrieval systems—without permission of the company.

© 2014



SILHOUET-TONE®

SILHOUET-TONE CORPORATION

2185, Michelin
Laval (Quebec) H7L 5B8 Canada
Tel. : 450 687-9456, 1 866 340-9456
Fax: : 450 687-5155
export@silhouettone.com

SILHOUET-TONE (CANADA)

1985, Monterey
Laval (Quebec) H7L 3T6 Canada
Tel.: 450 688-0123, 1 800 361-3004
Fax: 450 688-0803
info@silhouettone.com

SILHOUET-TONE (U.S.A.) INC

1623 NW 84th Avenue
Miami, Florida 33126 U.S.A.
Tel.: 1 800 552-0418
stusa@silhouettone.com

SILHOUET-TONE (EUROPE) S.A.

9, route Suisse, CH-1295-Mies, Suisse
Tel.: +41 22 775-15 60
Fax.: +41 22 775-15 67
ste@silhouet-tone.com

SILHOUET-TONE FRANCE Sarl

14, avenue du Dr Palluel
74160 St-Julien-en-Genevois, France
Tel.: +33 4 50 49 45 32
Fax.: +41 22 775-15 67
stf@silhouet-tone.com

www.silhouet-tone.com



* Sites: Tolhurst, Monterey, Michelin.