

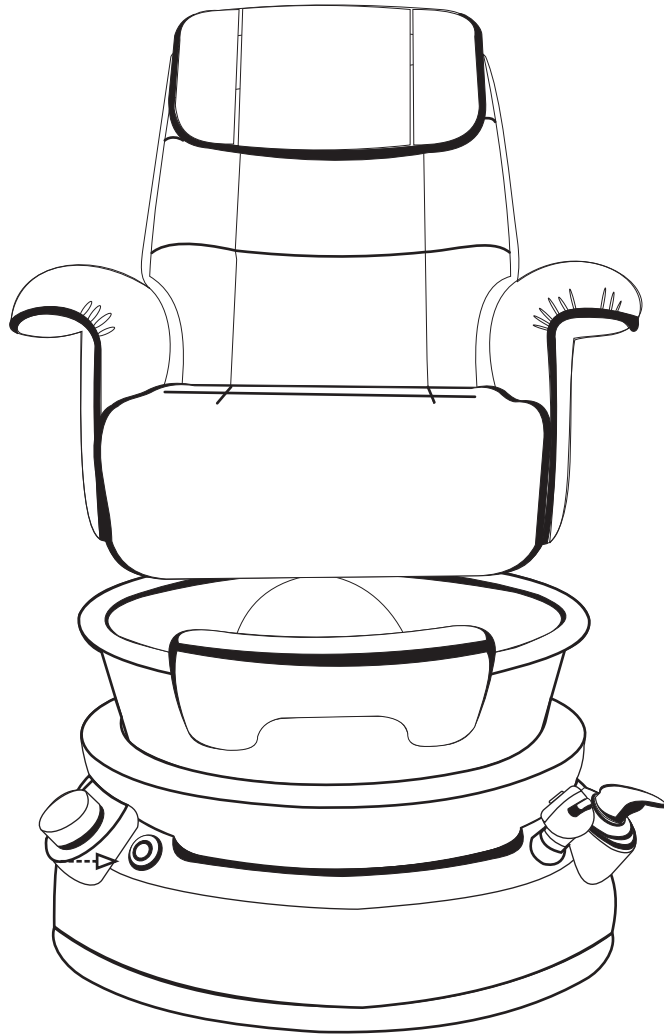

# DS

## OWNER'S MANUAL

Please read user's Manual thoroughly  
before using pedicure spa



## Table of Contents

Table of contents	2
Warranty form	3
Service inquiry form	4
Introduction & Safety	5
Important Consideration	6
Identify parts & Description	7
Specification	8
Dimension	9
Drain Connection	10
Summary	11
Magna-Jet Pipeless System	12 - 14
Power Discharge Pump	15
Remote Control & Recliner attachment	16
Disinfecting Pedicure Spa	17
User's Recommendation	18
UL Certification	19
Back Flow Prevention Device Dual Check Valve Information	20
JSG Oceana Implied Warranty	21
Warranty	22





**After Service Inquiry Form**

Please use inquiry form as all service request  
(Fill out all blanks and Fax or email us, our A/S Dept. will call you promptly)



Distributor Name: \_\_\_\_\_

Date \_\_\_\_\_

Phone Number: \_\_\_\_\_

Contact Person: \_\_\_\_\_

Salon Name: \_\_\_\_\_

Address: \_\_\_\_\_

\_\_\_\_\_

Phone Number: \_\_\_\_\_ Alternate Phone Number: \_\_\_\_\_

Contact Person: \_\_\_\_\_ Best time to reach: \_\_\_\_\_

Serial Number: \_\_\_\_\_

Brief Description of Problem: \_\_\_\_\_

\_\_\_\_\_

\_\_\_\_\_

\_\_\_\_\_

**J&A Service Official Use Only**

Technician Name: \_\_\_\_\_ Date: \_\_\_\_\_

Service Status: \_\_\_\_\_

\_\_\_\_\_

## Introduction

Thank you for purchasing the **Lenox** Whirlpool Pedicure Spa. This finest Whirlpool Pedicure Spa has been developed by J&A USA, inc. To operate dependably for many years when used properly. Please take time to read this manual thoroughly before installation and use.

## PLEASE READ AND FOLLOW INSTRUCTIONS CAREFULLY!

### Important Precautions

J&A USA requires that you contact your local, qualified electrician and plumber to install your **Lenox** Whirlpool Pedicure Spa. It cannot operate efficiently or safely unless it is provided with adequate electrical power, sufficient water pressure, proper water temperature and required drain facilities. Information on these important subject contained on this manual. We urge you to read it carefully to make sure these requirements are met.

### Precautions

1. Excessive water temperature is dangerous and should be checked before use. Maximum water temperature should Not exceed 105 degree F ( 41 degree C.).
2. Always enter and exit the whirlpool Pedicure Spa slowly and carefully.
3. Never bring and/or operate any electrical devices into or near the Whirlpool Pedicure Spa.
4. Do not stand in the Whirlpool tub!
5. This Whirlpool Pedicure Spa has a weight capacity of 250 lbs.

## WARNING

Do not use if you are diabetic, have poor blood circulation, or if any area of your feet or legs are inflamed or have open wounds. Consult a physician before using if you have any kind of fungal infection, swelling, fracture, or persistent pain.

MESSAGE SHOULD BE PLEASANT AND COMFORTABLE.

IF YOU EXPERIENCE PAIN OR DISCOMFORT, DISCONTINUE USE IMMEDIATELY AND CONSULT A PHYSICIAN

This product in whole is in compliance with applicable UL LISTED standards and requirements for the U.S and Canada By Underwriters Laboratories Inc.



Some of the components of this product are Also in compliance with applicbale Safety standards of following:



# Important Considerations

## Electrical Service

110V, 60Hz, 15Amp GFCI protected grounded circuit **MUST** be used to supply power each individual pedicure spa. And the main circuit breaker **MUST** be at 25Amp. For maximum of two units per each electrical outlet.

## Water Supply

All plumbing connections must conform to local codes.

Water supply to the spa should be provided with adequate water pressure and water temperature.

## Water pressure

To fill the basin correctly up to level, Normal water pressure of 30 to 80 P.S.I is required.

## Water temperature

The hot water supply temperature must not exceed 140°. Adjust your hot water accordingly. For hot and cold water supply fittings and drain fittings location, see below diagram .Carefully connect the water supply line to the appropriate fittings located on the rear of the pedicure spa.

## Pressure / Temperature

Maximum Pressure: 150 psi (10 bars)

Minimum Pressure: 10 psi (69kPa)

Working Temperature: 33F to 140F constant; intermittent to 180f

(0.6C to 60C sustained; intermittent to 82.2C)

Maximum Recommended Flow: 15gpm (57lpm)

## UL LISTED / CE CERTIFIED

Compliance with following Code (s): Uniform Plumbing Code, National Plumbing Code of Canada and international Plumbing Code. Also, Compliance with following Standard (s): ASME A112.18.3M / A112.18.1M, CSA B125, NSF / ANSI 61

ANSI - American National Institute, ASME - American Society of Mechanical Engineers, CSA - Canadian Standard Association IAPMO - International Association of Plumbing and Mechanical Officials, UL - Underwriters Laboratory

All J&A USA products has been compliance with requirements for Whirlpool bath appliances contained in ASME / ANSI A122.19.7M-1995, CSA C22.2 No. 68-69

## **\*\* Vaccum Breaker**

Due to Town and / or State requirement/s are varies in building code, if the Town and / or State requires Vaccum Breaker, As the Plumber **MUST** provide Vaccum Breaker according to building code requirement.

## Drain Facilities

The pedicure spa Drain must meet local plumbing codes. **Check valve for Drain (not Provided) Must be installed by a licensed plumber.** Also Pedicure spa must be securely fasten to the floor.

## Installation Summary

The installation must comply with local, state, and federal building, plumbing and electrical codes, where applicable. A licensed plumber should complete the plumbing of the pedicure spa.

Note: Failure to comply with federal, state, or local codes and ordinances will result in warranty being nullified and void.

**IDENTIFICATION**

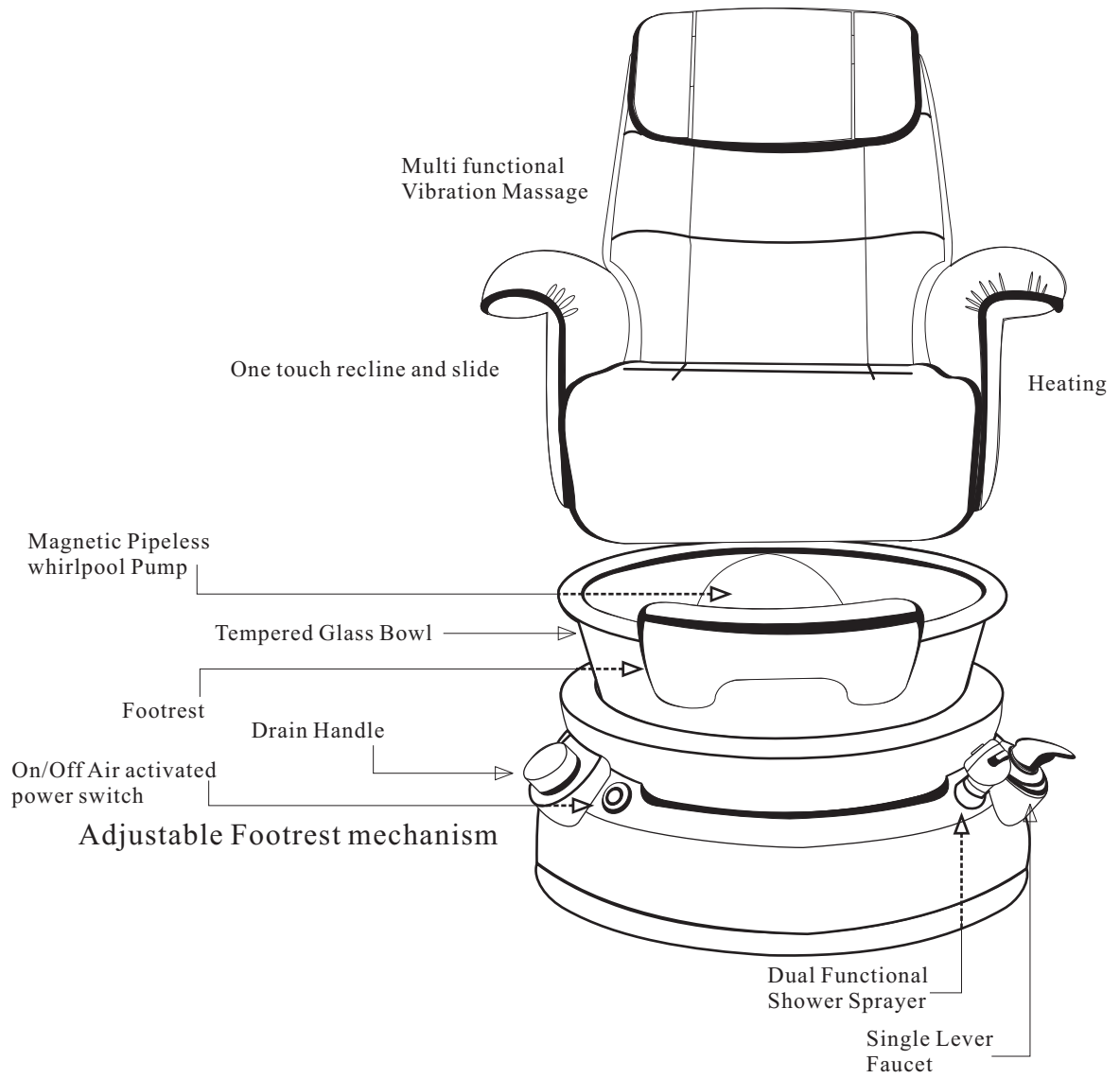

**BASIN**

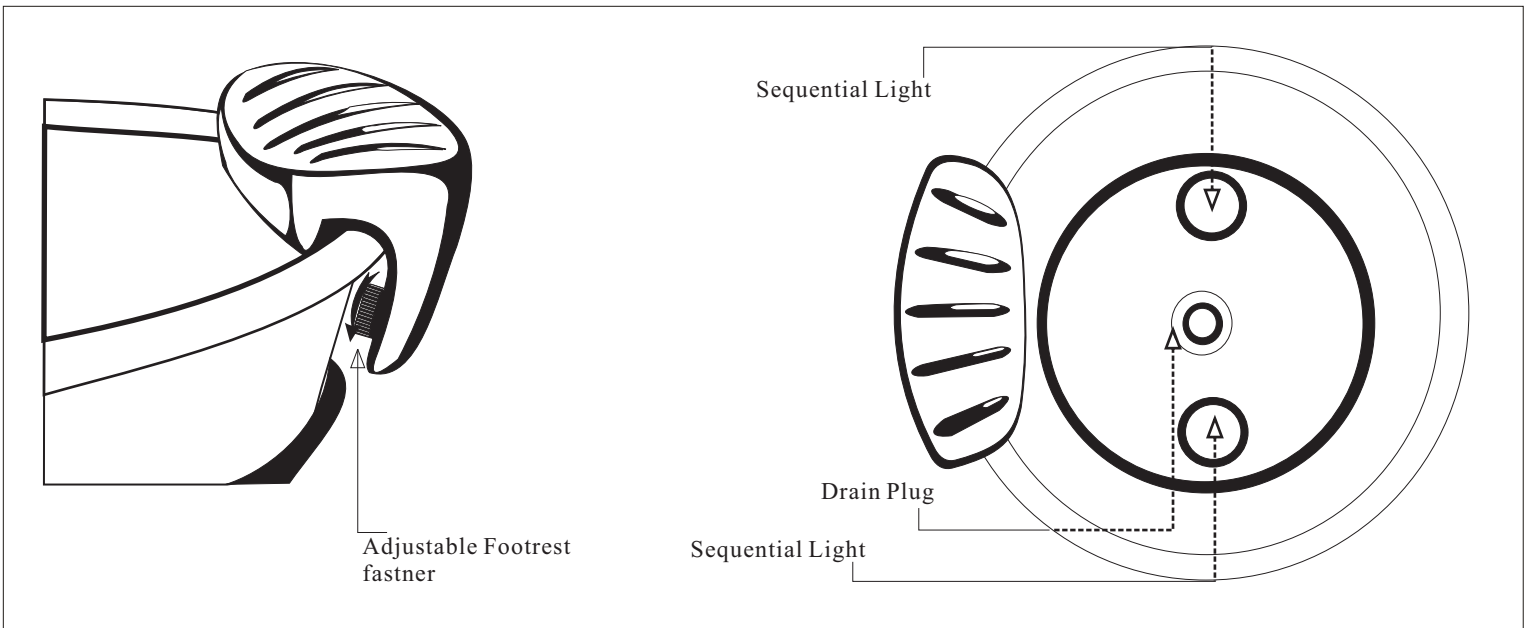

# Specification

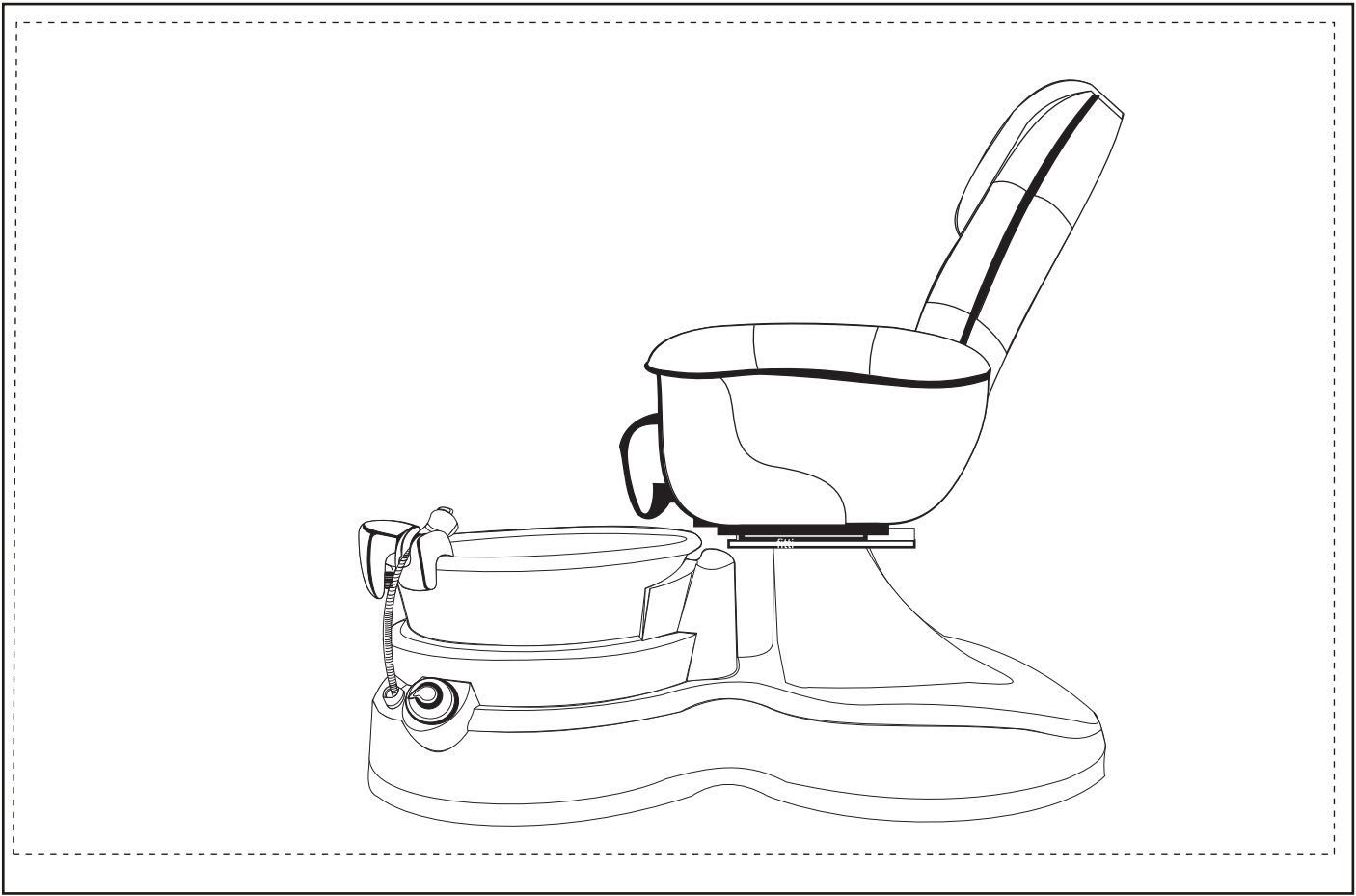

**CAUTION: Pedicure spa must be installed by a licensed electrician and a licensed plumber, conforming to all local and national electrical codes.**

Dimension & Weight (Shipping)	Lenox Pedicure Spa Stool	67L x 37W x 40H 20.25L x 27.25W x 17H	250lbs 20lbs
Capacity of Tub Switch	Lenox	On/Off Air Activated Switch	
Power Source	Dedicated 15 Amp. GFCI protected Ground outlet Magna-Jet Pipelss Massage System	115 Vac. 60Hz. 3.2 Amp. 120 Vac. 60Hz.	
Plumbing	Hot Water Cold Water Drain	0.5 inches (Fitting Provided) 0.5 inches (Fitting Provided) 1.5 inches (See detailed instruction)	
Warranty	Epi - Lenox Pedicure Spa	One year Parts and labor	

All J&A products are equipped with Back Flow Prevention Device Dual Check Valve  
WATTS 3/8 7,7C and 3/4 H7, H7C (tested and certified to meed ANSI/ASSE standard 1024.)

Due to continuous improvement on all our products, followings are subject to change without notice: specification, characteristics, packing, information, color and design



# Dimension

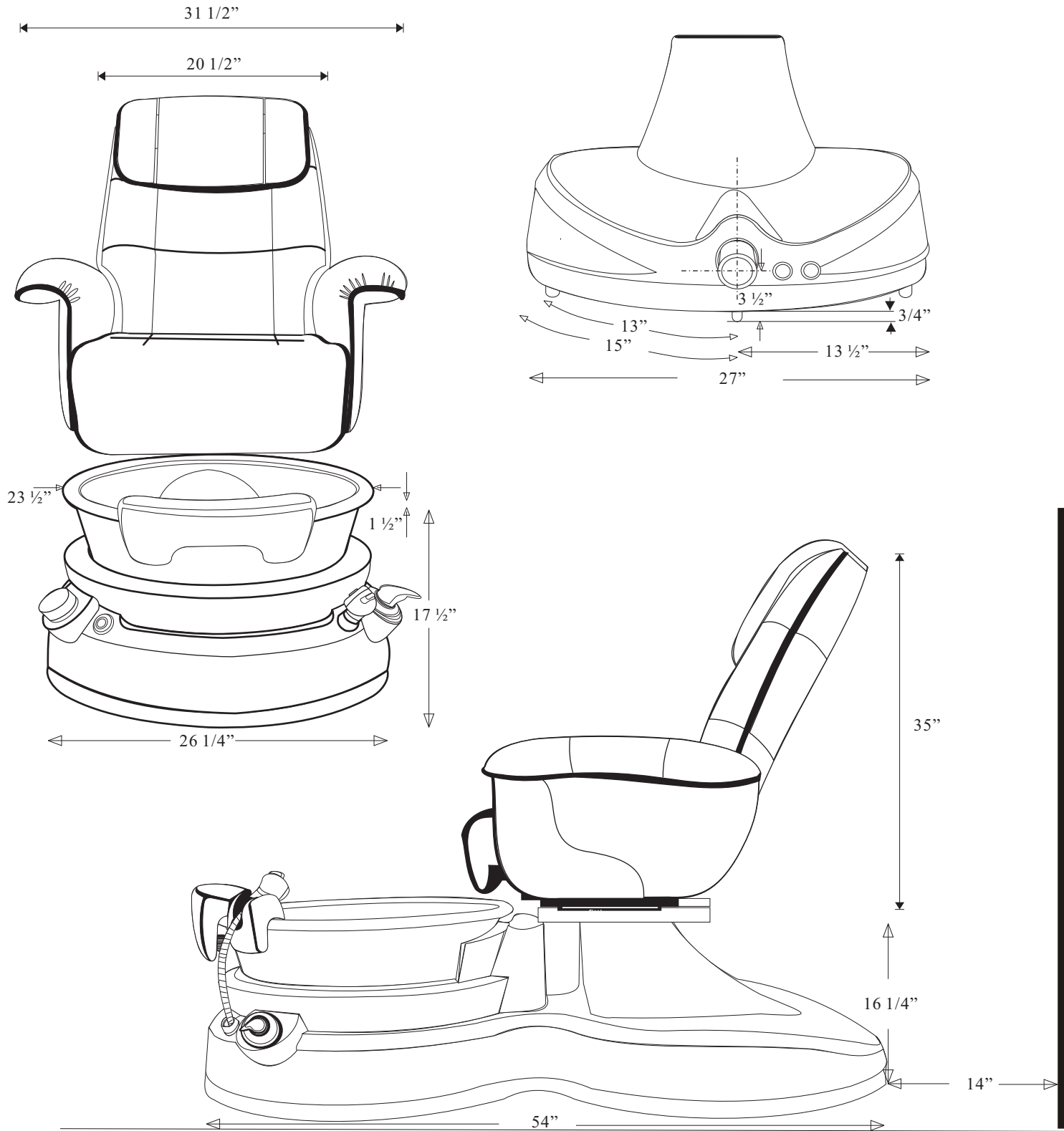

Manufactured by :	Model :
J&A USA Inc.,	LENOX DS
Dimensions:	Prepared by :
Rear/Side	J&A USA Inc.

## Drain Connection

Wall Drain

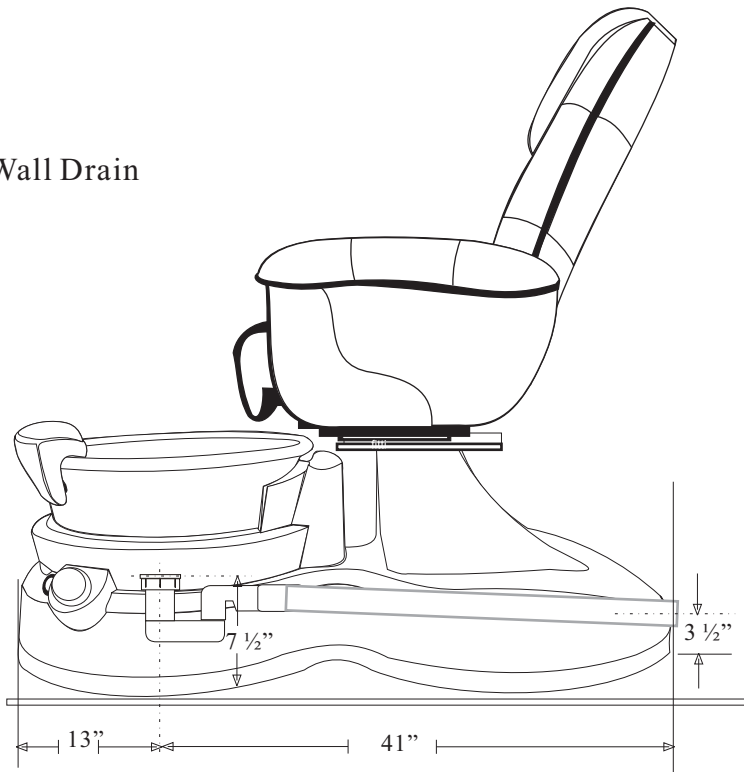

Rear View

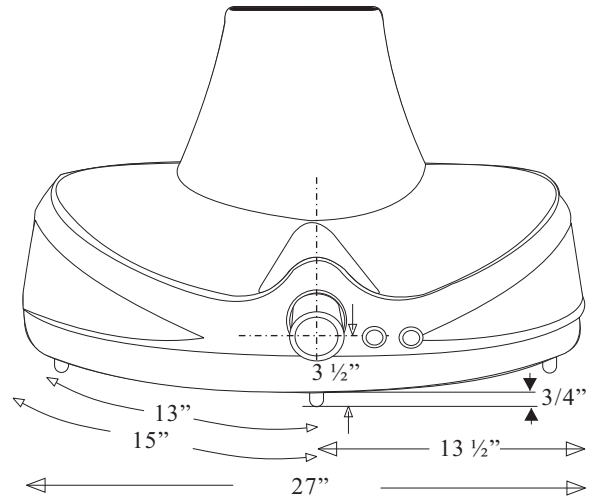

Discharge Pump

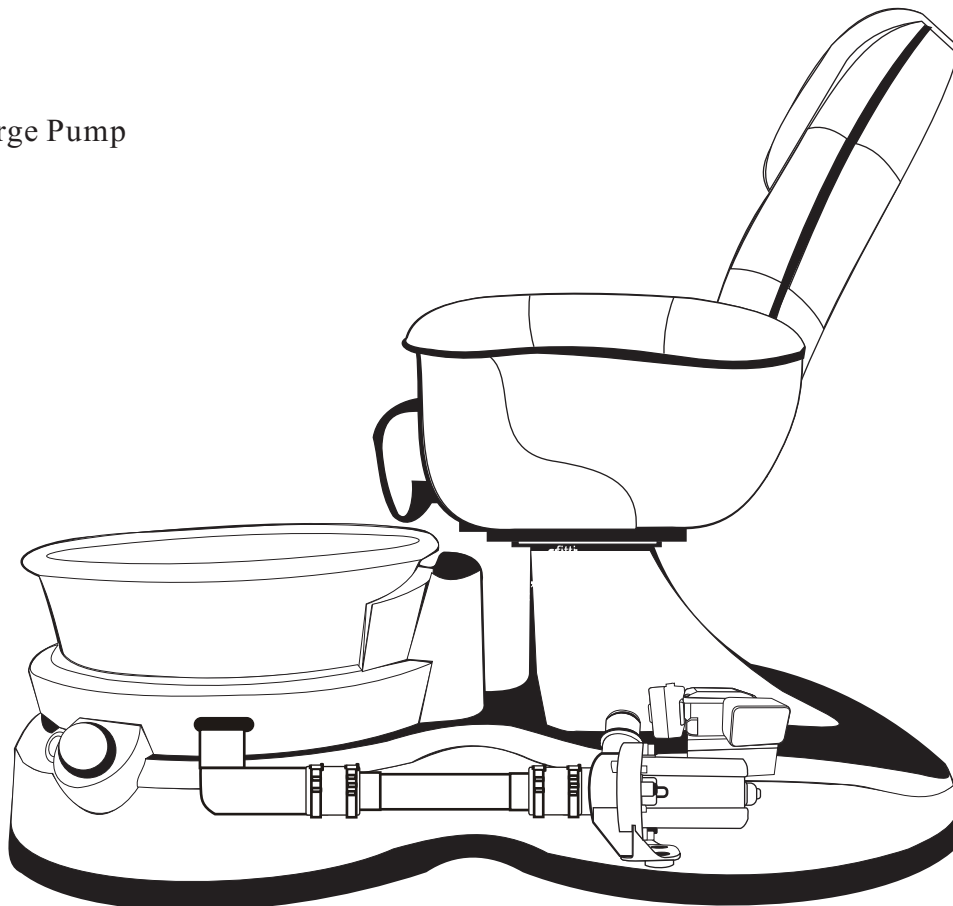

## Installation Specifications Summary

**Warning:** Failure to comply with federal, state or local codes and ordinances will result in warranty being null and void.

As stated, the pedicure spa installation must comply with all plumbing and electrical codes. A licensed plumber and licensed electrician must complete the applicable connections of the pedicure spa.

### Location and support

Select a level location. The floor structure beneath the pedicure spa must be capable of supporting the occupied pedicure spa.

For the seat back to fully recline, the pedicure spa base must be mounted as follow from the wall as shown below:

\*\*\* When chair slide all the way back – would require 14 inches from the wall\*\*\*

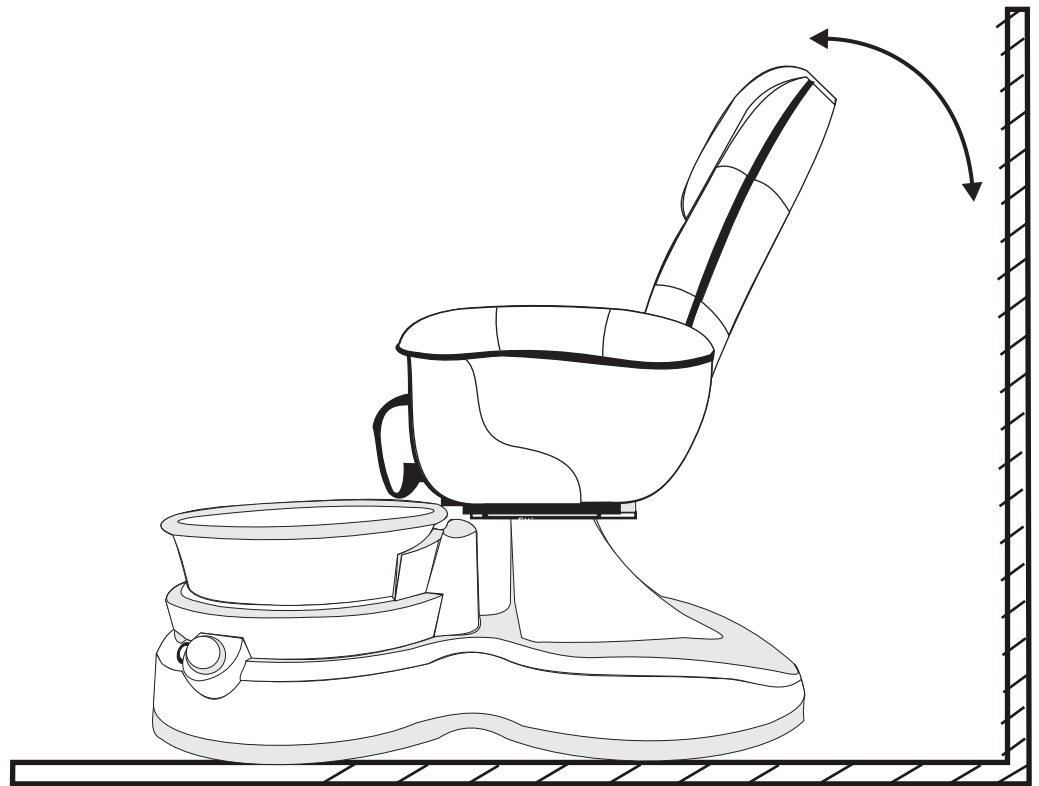

Due to continuous improvements on all our products, specification, characteristics, packing, color, designs are subject to change without notice.

## MAGNA-JET (OPTIONAL)

### Safety Instructions

When using electrical equipment, Basic safety precautions must be followed to reduce the risk of fire, electrical shock, and injury to Persons.

1. Read and follow all instructions before using the equipment.
2. Keep electrical cord out of heavy traffic area. To avoid fire hazard NEVER place electrical cord under the rug, near heat Generating devices.
3. Always turn power off the equipment before service.
4. Do not drop or insert any object into any openings.
5. Do not operate any equipment with damaged parts.
6. Any other use not recommended by the manufacturer may cause electrical shock or cause injury to person/s.
7. Never use it outdoors
8. Do not attempt to repair or adjust any electrical or mechanical.

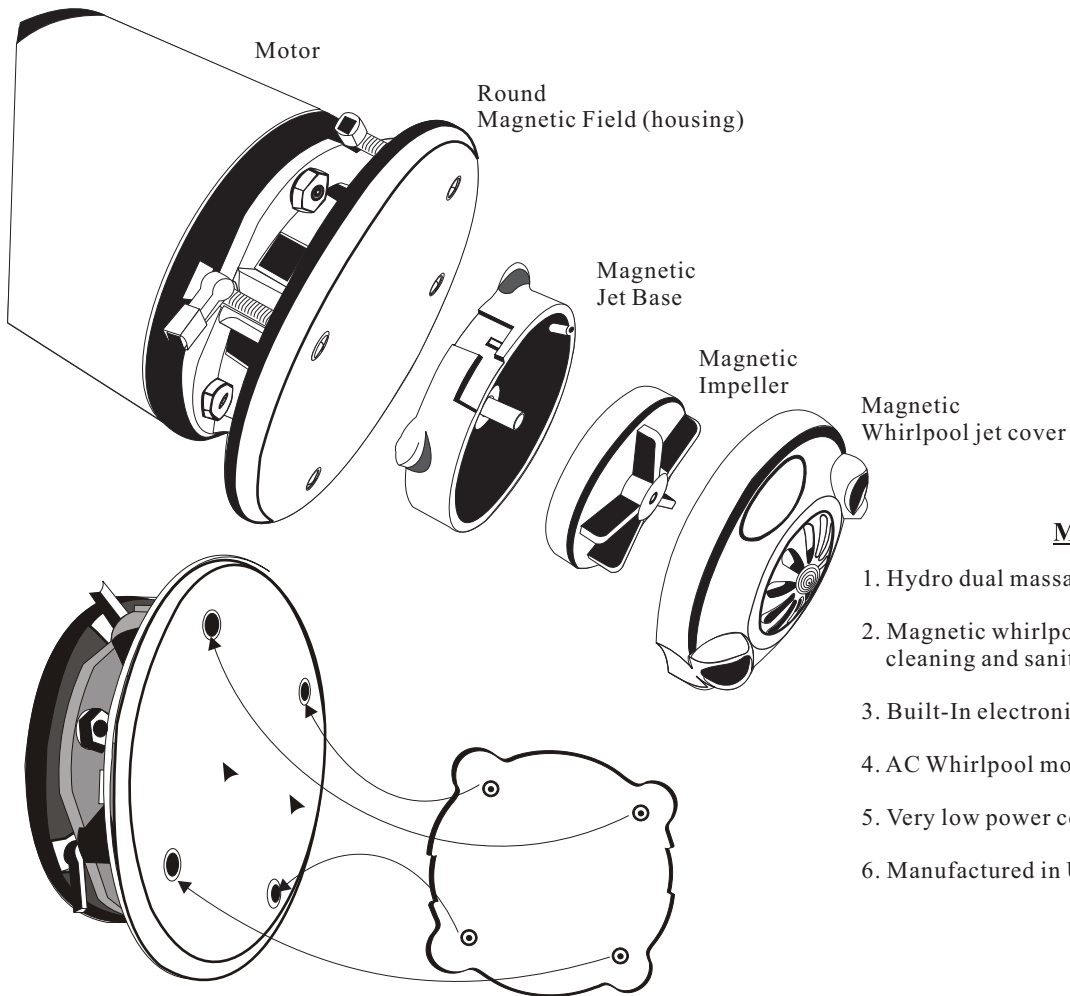

### MAGNA-JET Features

1. Hydro dual massage jet stream
2. Magnetic whirlpool jet cover can be remove for quick cleaning and sanitizing.
3. Built-In electronic sensor for pump control.
4. AC Whirlpool motor (long life)
5. Very low power consumption (27W)
6. Manufactured in USA.

### Cleaning Instruction

1. Turn off the unit and wait until the motor is fully stops.
2. Hold Hydro whirlpool jet cover firmly and pull to separate from the round magnetic field.
3. Turn hydro whirlpool jet cover to left to open and pull out impeller.
4. Use Anti - Bacterial solution (EPA Registered) to clean all parts.
5. After sanitize all parts, place impeller and close hydro whirlpool jet cover to turn right to lock
6. Hold firmly the whirlpool cover jet and gently place it onto the round magnetic field. Do not release the hydro whirlpool jet cover until Jet cover is on the round magnetic housing.

### MAGNA-JET Specifications

Model: MAGNA-JET - 120VAC, 60Hz, 1.0Amp, 27W

Pump: Hydro-Massage Dual jet Flow

Mounting: Single 3.5" hole Diameter  
Auto tighten Mounting screws(4)

## How to USE Magnetic jet !

**WARNING:** DO NOT RUN DRY, BASIN MUST FILLED WITH WATER TO LEVEL INDICATOR.

**CAUTION: MAGNETIC JET COVER ASSEMBLY MUST ALIGN WITH DISCHARGE PORT POSITIONED AT 3/9 O'CLOCK.**

WHEN READY TO USE, **MAKE SURE** JET COVER IS POSITIONED AT **3 /9 OCLOCK** FOR PROPER WHIRLPOOL ACTION IN THE BASIN. IF JET COVER IS **NOT** ALIGN AT 3/9 O'CLOCK, WATER WILL SPLASH OUTSIDE OF THE BASIN.

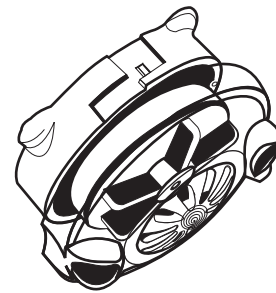

### **PROPER WAY TO USE MAGNETIC JET SYSTEM**

- 1- FILL THE WATER TO WATER LEVEL INDICATOR.
- 2- HOLD MAGNETIC JET FIRMLY TO BRING CLOSER TO THE ROUND MAGNETIC FIELD AND DO NOT RELEASE THE MAGNETIC JET PREMATURELY OR THIS WILL CAUSE IMPACTS ON THE JET COVER AND THE ROUND MAGNETIC FIELD(HOUSING) SHORTENING THE LIFE EXPECTANCY OF THE JET COVER. WHEN THE JET COVER NEARS THE ROUND MAGNETIC FIELD, PLACE JET COVER ONTO THE FOUR DIMPLE AREA (SEE DIAGRAM). THE JET COVER MUST ALIGN WITH DISCHARGE PORTS POSITIONED AT 3/9 O'CLOCK.
- 3- WHEN FINISHED WITH CLIENT, DO NOT REMOVE MAGNETIC JET UNTIL MOTOR IS FULLY STOPPED.
- 4- WHEN MOTOR IS FULLY STOPPED, REMOVE MAGNETIC JET COVER FROM THE MOTOR AND REMOVE JET COVER AND IMPELLER FOR SANITIZATION.

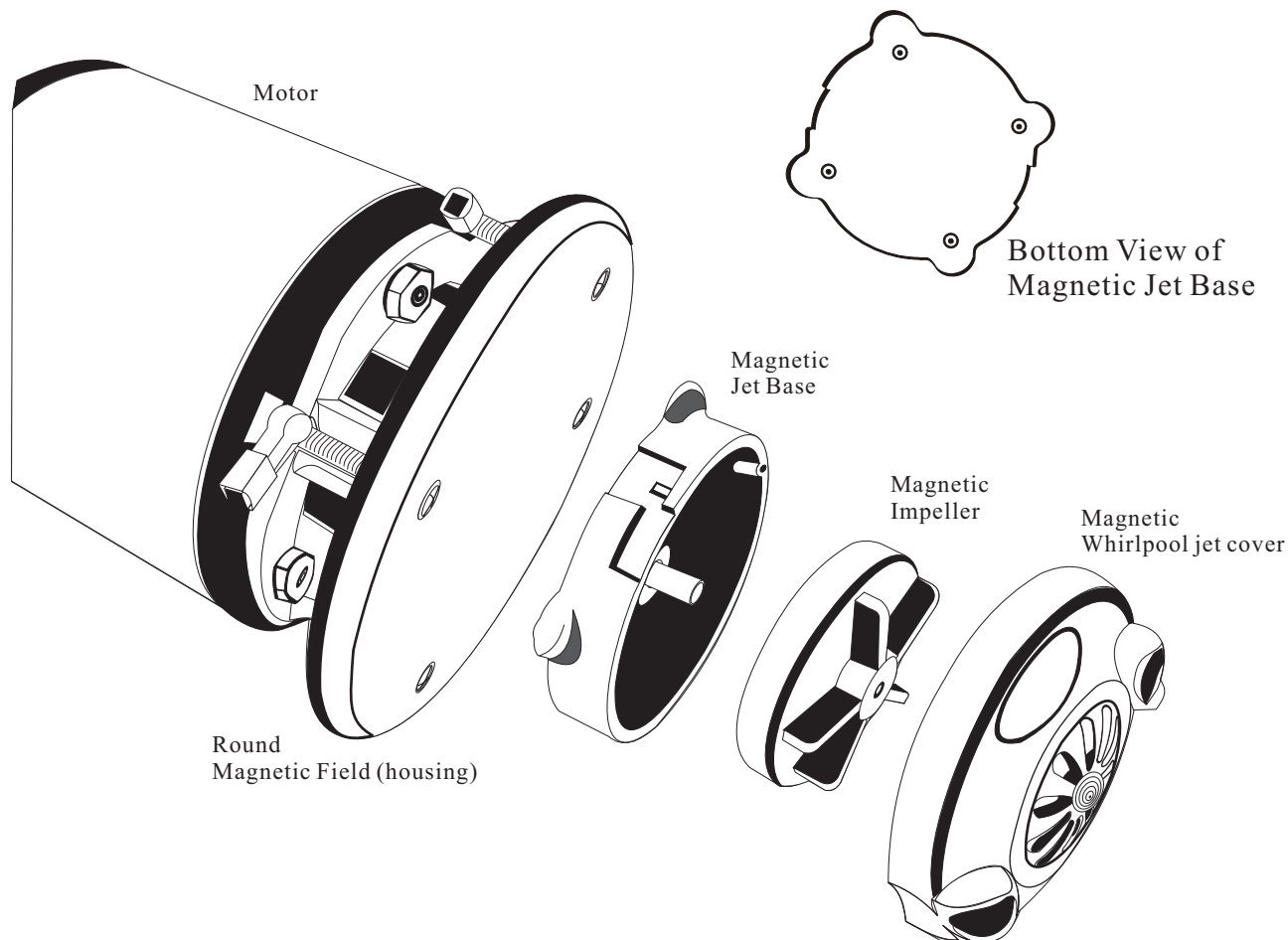

# Dura-Jet III

## Safety Instructions

**When using electrical equipment, basic safety precautions should always be followed to reduce the risk of fire, electrical shock, and injury to persons, including the following:**

1. Read and follow all instructions before using the equipment.
2. Keep the cord out of heavy traffic area. To avoid fire hazard NEVER put the cord under the rugs, near heat generating devices.
3. Always turn off the equipment before servicing.
4. Do not drop or insert any object into any openings.
5. Do not operate any equipment with a damage parts.
6. Any other use not recommended by the manufacturer may electrical shock or injury to persons.
7. Never use outdoors
8. Do not attempt to repair or adjust any electrical or mechanical functions on the unit.

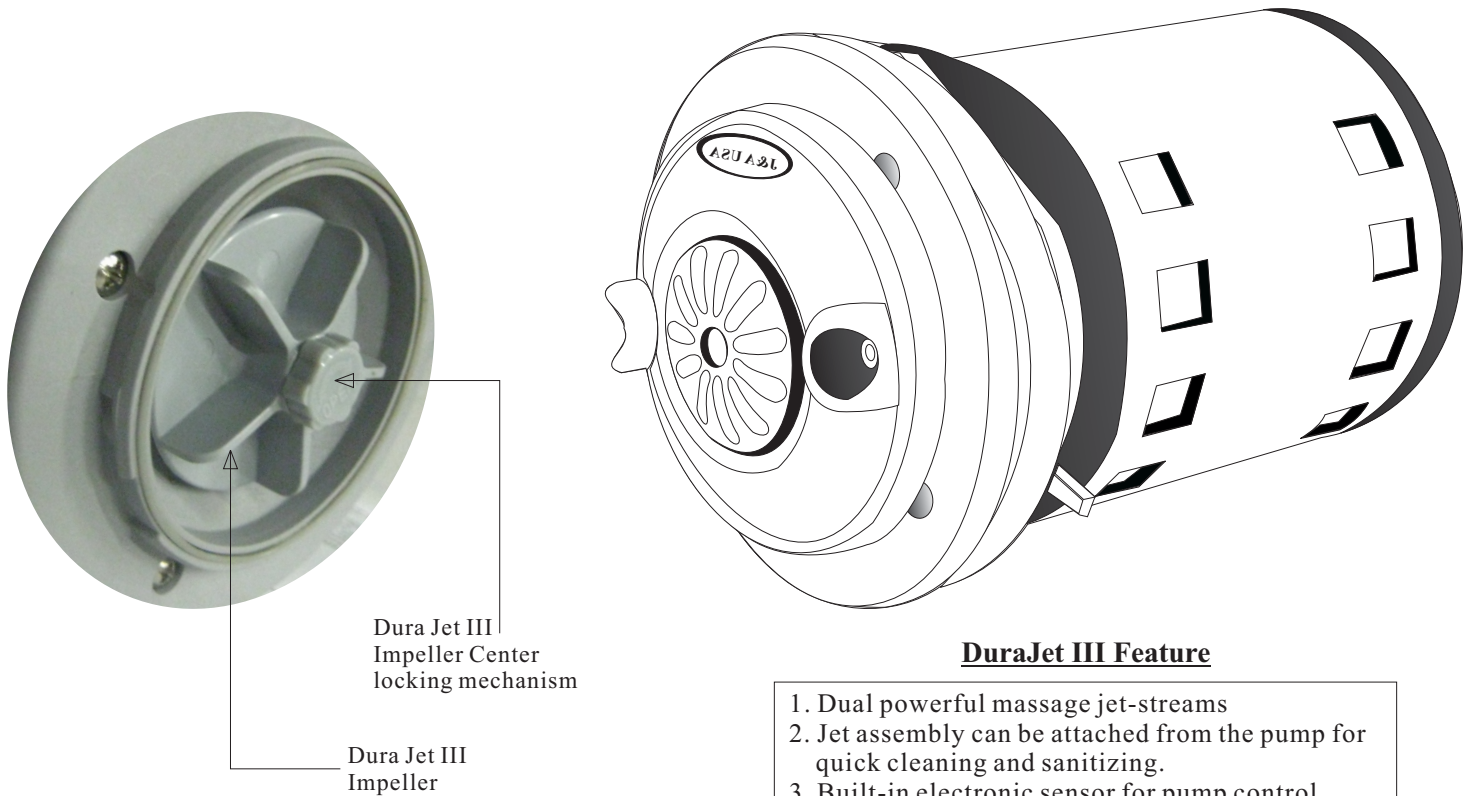

## Cleaning Instruction

1. Turn the unit off and wait until the motor is fully stops.
2. Remove the front jet cover and notice the locking screw in the center
3. Remove the locking center screw (turn counter clockwise) and pull out impeller from housing.
4. Use Anti-Bacterial solution (EPA Registered) to clean all part/s.
5. After sanitization, place impeller onto the motor shaft and fasten with center locking screw ( Turn clockwise)

## DURA-JET III Specifications

Model: DURA\_JETIII -120Vac, 0.4 Amp. 60Hz,

Pump: Dual Air Jet Flow

Mounting: Single 3.5" hole Diameter  
Auto tighten Mounting screws(4)



# DS Discharge Pump

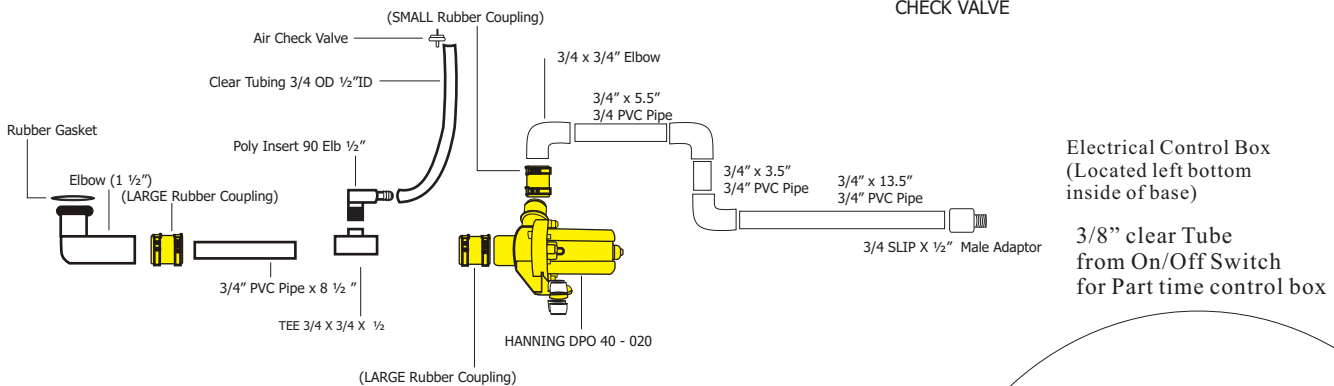
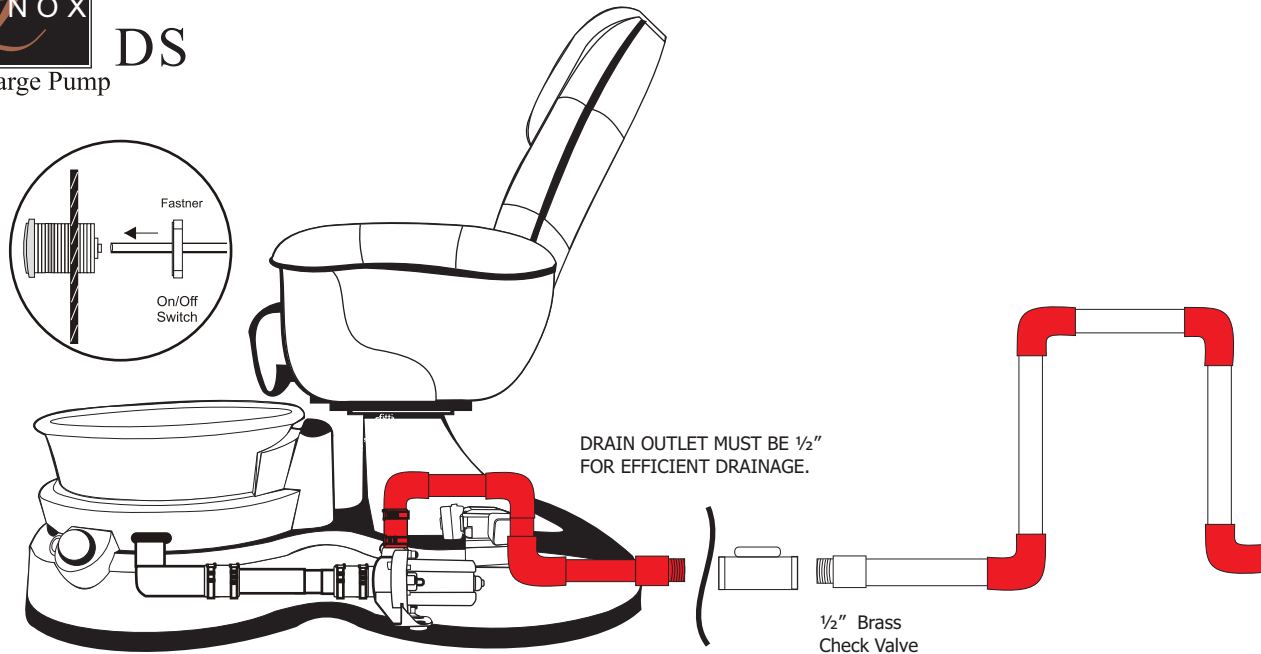

## Installation Instruction

1. Make a hole ( size 1-3/8") for the On/Off switch as shown (see fig 1). Pre-drill required.
2. Placed a 1/8" clear hose into the rear of the switch and on/off switch into the hole.
3. The discharge pump kit is made to fit onto the pedicure unit. (see fig 2)
4. Connect E-Z connector onto the drain elbow.
5. Plug discharge pump outlet into the two minute timer outlet
6. Plug two minute timer into the wall outlet.
7. It is very important that tip of the clear tub remain above the water Level with one loop as shown.

**\*\* Please cut to fit 1" Flex hose to your size\*\***

## Operation Instruction

**Please! DO NOT run dry**

1. Turn to open drain plug.
2. Press On/Off switch to activate timer.
3. At any time, water drain completely from the basin. Press On/Off switch to stop or built in two minute timer

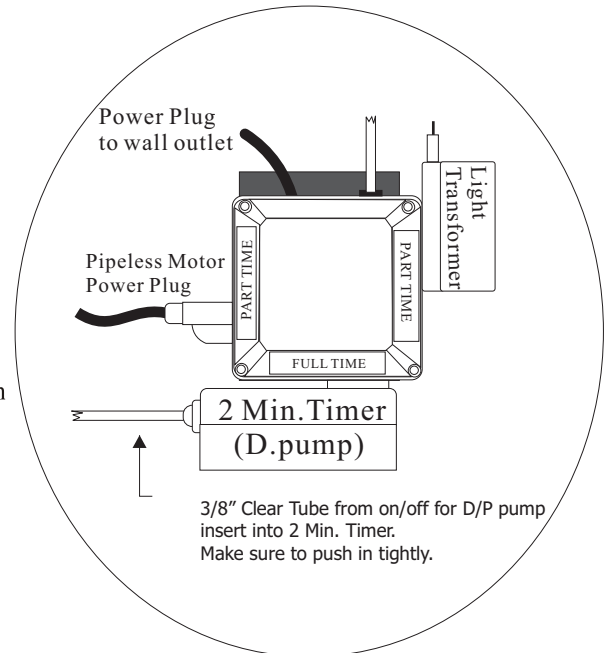

## Recliner Piston End Attachment Instruction

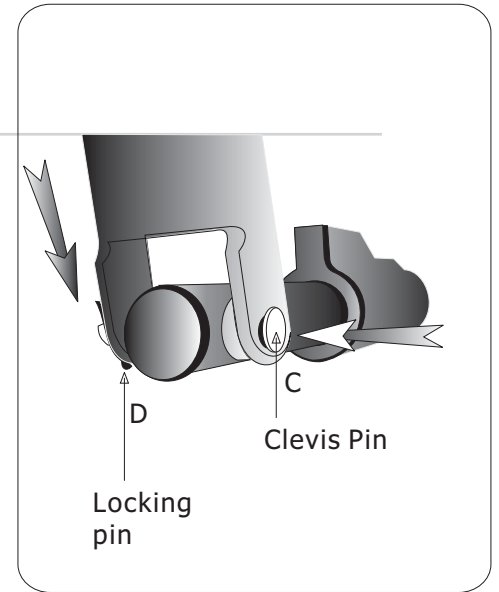
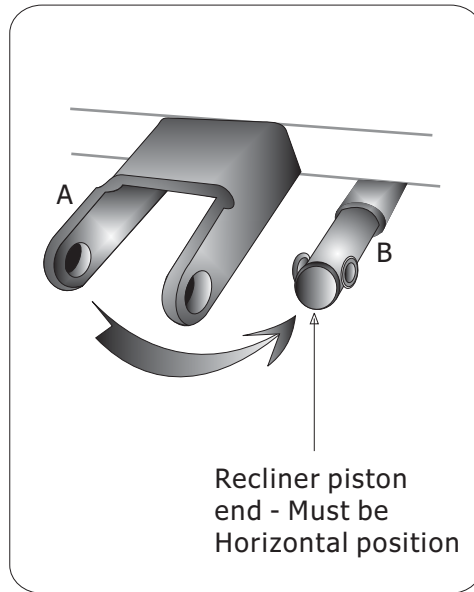
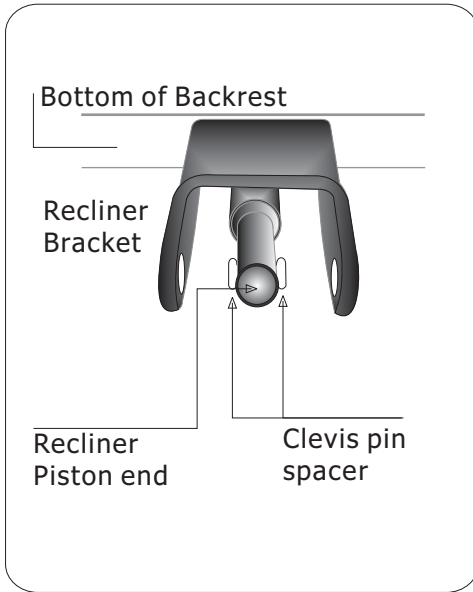

1. Remove Clevis pin from recliner piston end and make sure it is in horizontal position.
2. Slowly raise up the backrest to aligned with recliner piston.
3. Insert Clevis Pin into the backrest bracket through recliner piston and secure with locking pin.

## Recliner Piston End Attachment Instruction

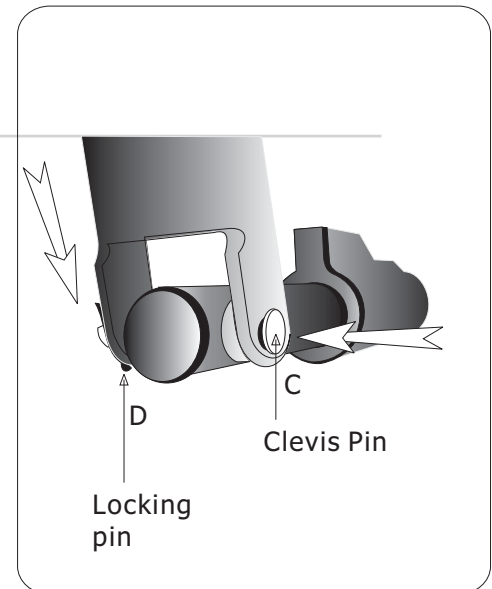
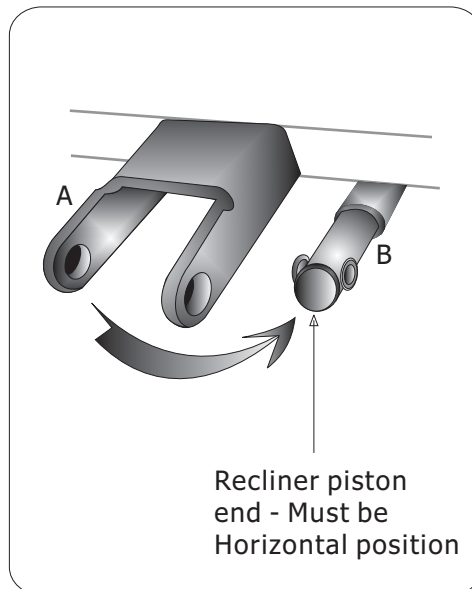
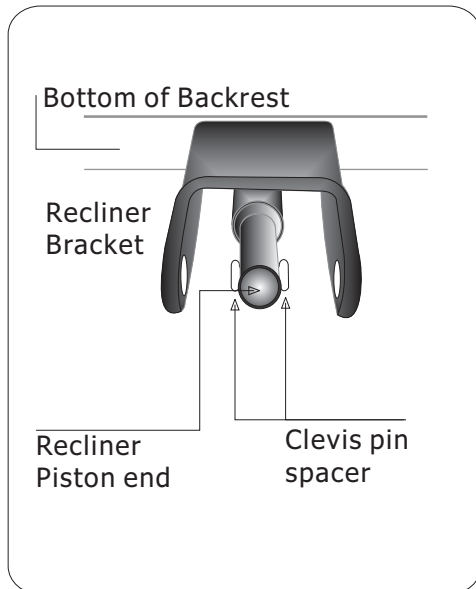

1. Remove Clevis pin from recliner piston end and make sure it is in horizontal position.
2. Slowly raise up the backrest to aligned with recliner piston.
3. Insert Clevis Pin into the backrest bracket through recliner piston and secure with locking pin.



## Chair Position Remote Controller

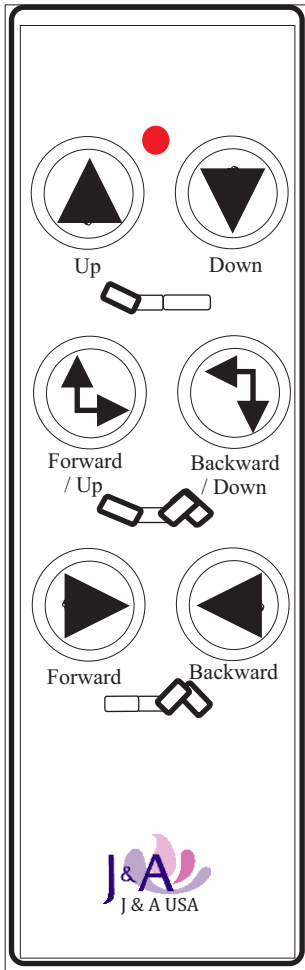

### Operation:

Press function button till preferred chair position, then release button.

### Function Button

- \* Up: Incline Chair back.
- \*Down: Recline Chair Back.
- \*Forward/Up: Forward chair seat and incline chair back at same time.
- \*Backward/Down: Backward chair seat and recline chair back at same time.
- \*Forward: Move chair seat forward.
- Backward: Move chair seat backward.

### Relaxor Vibration Remote control

#### **POWER**

Activates Massage System  
 \* Turn On :Press PWR  
 \*Turn Off: Press PWR again

#### **15 and 30 minute Timer**

Green Light = 15 minute Timer  
 Hold Down PWR  
 Amber light = 30 minute Timer

\*Unit may also be turn on by pressing  
 Either ZONE key.

To start after timer shuts off:  
 \*Press PWR or either ZONE key.

#### **MODES**

(Green light indicates active Mode)

#### **SELECT-**

Let you choose zones for steady massage

- \*Press SELECT
- \*Press either or both Zones to activate.
- \*Press either or both Zones to cancel.

#### **PULSE-**

Massage motor turn on and off to provide a pulsing action.

- \*Press Pulse
- \*Press either or both Zones to activate.
- \*Press either or both Zones to cancel.

#### **WAVE-**

Massage motors move up and down in a wave-like motion.

- \*Press WAVE
- \*Press both Zones to activate.
- \*Press any other MODE to cancel.

#### **HEAT**

Activates Heat.  
 \*Press LO (Amber light) to turn low heat on.  
 \*Press HI (red light) to turn high heat on.

Works with massage or independently.  
 30 minute timer.  
 To continue after Time shuts off, press LO or HI  
 button again.

#### **ZONES**

(Green light indicates active Zone)  
 1- Zone 1 once to activate massage.  
 Press again to deactivate.  
 2- Zone 2 once to activate massage.  
 Press again to deactivate.

**The location of each zone varies with  
 individual chair style.**

#### **INTENSITY**

Controls INTENSITY during all modes.  
 Press (+) increase intensity; (-) decrease intensity.

#### **SPEED**

Controls pulsing frequency of massage motors in  
 PULSE mode and controls the velocity as it cycles  
 through in WAVE mode.

Press (+) to increase and (-)decrease speed.

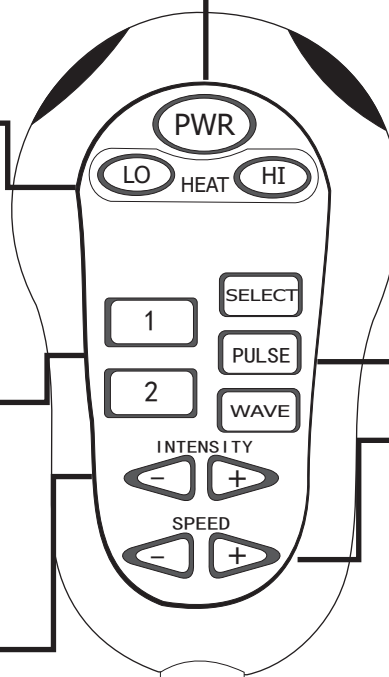

## **DISINFECTING YOUR PEDICURE SPA**

**Note:** Please be advised that it is responsibility of purchaser/user to adhere strictly to the following procedure. Any non-compliance will be considered negligence of the purchaser/user.

The Bureau of barbering and cosmetology requires that salons using whirlpool pedicure spas use the following disinfecting Procedures to ensure proper cleaning and maintenance of the equipment, and to prevent bacterial infection.

### **After each customer:**

1. Drain all water and remove all debris from the pedicure spa.
2. Clean the surfaces and walls of the basin with soap or detergent and rinse with clean, clear water.
3. Disinfect with an EPA - registered disinfectant with bactericidal, fungicidal, and virucidal activity.
4. Wipe dry with clean towel.

### **At the end of the day:**

1. Remove the intake suction screen, All debris trapped behind the screen of each pedicure spa must be removed. And the screen and the inlet shall be washed with soap or detergent and water
2. Before replacing the screen, Totally immersed the screen into an EPA- registered disinfectant with bactericidal, Fungicidal, and virucidal activity.
3. Finally, flsh the whirlpool system with low-suding detergent and warm OR an EPA - registered cleanser for 10 minutes. Rinse with clean flash water and drain.

### **Every other week**

1. After following the outlined required cleaning procedures for the end of each day, fill the basin with warm water And 1 teaspoon of 5.25% powdered bleach for each one gallon of water.
2. Circulate the solution through the whirlpool system for 5 to 10 minutes.
3. The solution rests for over night (at least 6-10 hours)
4. The following morning ( before the first customer) drain and flush the system with water.

## USER RECOMMENDATION

PLEASE READ THE MANUAL THOROUGHLY BEFORE USE TO ENSURE CORRECT OPERATION.

THOSE UNDER A DOCTORS CARE OR WHO ARE EXPERIENCING ONE OR MORE OF THE FOLLOWING DONDITIONS SHOULD CONSULT THEIR DOCTOR BEFORE USE.

- You are receiving medical treatment or are feeling ill.
- Your body shows any cute symptoms.
- You have heart disease.
- You are pregnant or having a menstrual period.
- Your doctor has ordered you to rest.
- You have a back disorder resulting from an accident or disease.
- You have a high fever.
- You have sensory disorders.
- You have medical electrical device (e.g. pacemaker).
- You have service interruption in the circulation of the legs.
- You are diabetic.

FAILURE TO DO SO MAY RESULT IN ACCIDENTS AND HEALTH PROBLEMS.



# CERTIFICATE OF COMPLIANCE

**Certificate Number** 20140428-E242637  
**Report Reference** E242637-20040930  
**Issue Date** 2014-APRIL-28

**Issued to:** J & A USA INC  
335 CROOKED HILL RD  
BRENTWOOD NY 11717

**This is to certify that  
representative samples of**

PLUMBING ACCESSORIES  
USL, CNL - Commercial-type, Whirlpool Pedicure Spas,  
Models Cleo, Episode S-type, Lenox, Pacific and Petra  
Model designation may be followed by any two-letter suffix,  
not related to safety such as finish, special features etc

Have been investigated by UL in accordance with the  
Standard(s) indicated on this Certificate.

**Standard(s) for Safety:** Standard for Electric Plumbing Accessories, UL 1951  
Standard for Motor Operated Appliances (Household and  
Commercial), CSA C22.2 No. 68-09

**Additional Information:** See the UL Online Certifications Directory at  
[www.ul.com/database](http://www.ul.com/database) for additional information

Only those products bearing the UL Listing Mark for the US and Canada should be considered as  
being covered by UL's Listing and Follow-Up Service meeting the appropriate requirements for US  
and Canada.

The UL Listing Mark for the US and Canada generally includes: the UL in a circle symbol with "C" and  
"US" identifiers:  the word "LISTED"; a control number (may be alphanumeric) assigned by UL;  
and the product category name (product identifier) as indicated in the appropriate UL Directory.

Look for the UL Listing Mark on the product.



William R. Carney, Director, North American Certification Programs  
UL LLC

Any information and documentation involving UL Mark services are provided on behalf of UL LLC (UL) or any authorized licensee of UL. For questions, please  
contact a local UL Customer Service Representative at [www.ul.com/contactus](http://www.ul.com/contactus)





### Back Flow Protection Device (Dual Check Valve)

May.1.2014

In accordance with applicable Local or State regulations,  
J&A USA Inc., The manufacturer of the pedicure whirlpool spa certifies that the following models are  
equipped with factory installed Dual Check Valve back flow preventer:

- \*\* Lenox Series
- \*\* Cleo Series
- \*\* Episode Series
- \*\* Pacific Series
- \*\* Petra Series
- \*\* Toepia Series

The specification of the installed device is as follows:

DEVICE NAME	DUAL CHECK VALVE BACKFLOW PROTECTION
DEVICE MANUFACTURER	NEOPERL INC. Waterbury CT.
DEVICE MODEL	Dual Check Valve 1/2" x 1/2"NPT
DEVICE SPECIFICATION	TESTED AND CERTIFIED TO MEET NSF/ASSI 61 Complies with ANSI/ASME A112.18.3M, A112.18.1M AND CSA B125
DEVICE PRESSURE	MAXIMUM PRESSURE: 150 PSI (10 BAR) SERVICE PRESSURE : 80 PSI
DEVICE TEMPERATURE	MAXIMUM TEMPERATURE : 150F SERVICE TEMPERATURE : 90F

ALL MODELS OF PEDICURE SPA MENTIONED ABOVE ARE EQUIPPED WITH THE SUBJECT DEVICE AS STANDARD FEATURE. As for your information, indicated State requires Vaccum Breaker.

\*\* Effective April 01 2005:

ARIZONA, CALIFORNIA, NEBRASKA, NEVADA, OREGON,  
TEXAS AND WASHINGTON

\*\* Effective June 15 2005:

ILLINOIS, MINNESOTA, WISCONSIN, MICHIGAN

\*\* Effective May 01 2007:

CONNECTICUT

For additional information, Please contact us at 631-243-5300  
Very Truly yours,

Technical Support

J&A USA Inc.

335 Crooked Hill Road  
Brentwood, NY 11717  
Tel: 631.243.3336  
Fax: 631.243.3339

www.jausainc.com

## Glass bowl Care and Cleaning

### CARE AND CLEANING

Clean the surface of your *JSG Oceana* glass product with mild soap and warm water. Wipe the entire surface completely dry with a clean, soft cloth.

### MANUFACTURER'S RECOMMENDED DRAIN INSTALLATION

Drain installation requirements will vary by supplier basin and unit. Manufacturer's drain installation instructions suggest to apply plumber's putty under rim of drain and hand-tighten drain only. DO NOT OVER - TIGHTEN.

### EXCLUSIVE WRITTEN WARRANTY

#### LIMITED ONE - YEAR WARRANTY

*JSG Oceana* Glass products are warranted free of manufacturing defects. *JSG Oceana* LLC will, at its election, repair, replace, or make appropriate adjustment where *JSG Oceana* LLC inspection discloses any such defects occurring in normal usage within one year after installation. *JSG Oceana* is not responsible for installation or removal costs. Proof of purchase requires the original sales receipt from the original consumer purchaser and must accompany all warranty claims.

**Implied warranties, including that of merchantability or fitness for a particular purpose, are expressly limited in duration to the duration of this warranty. *JSG Oceana* LLC disclaims any liability for special, incidental or consequential damages.**

Some States do not allow limitation on how long an implied warranty lasts or the exclusion or limitation of special, incidentals, or consequential damages, so these limitations and exclusions may not apply to you. This warranty gives you specific rights. You may also have other rights which vary state to state. This limited warranty provides specific legal rights as they apply within U.S.A, and other rights may be available, but may vary from country to country.

**Crystalline material and air bubbles are a unique characteristic of art glass. They are an inherent part of the glass making process and are not detrimental to the mechanical strength or function of the glass basins. Each piece of *JSG Oceana* is individually inspected for durability and superior performance.**

## Limited Warranty Pedicure Spa

### **IMPORTANT**

To validate the limited warranty, The Limited Warranty Registration Form **MUST** be filled out completely and return to J&A USA within 30 days of original purchased date. This Limited Warranty is valid if J&A USA received registration form.

J&A USA Inc. Pedicure Spas has designed and manufactured with the highest standards and expressly warrant the pedicure spa as follows:

To the original owner of the J&A USA Inc. Pedicure Spa may repair or replace, at its option, any pedicure spa found to be defective in material or workmanship upon inspection by a authorized representative of J&A USA Inc. This limited warranty covers the following:

**Base** - Twenty four (24) month from date of shipment from J&A USA facility.

**Components / Parts** - Twenty four (24) month from date of shipment from J&A USA facility.

**Stool** - Ninety (90) days from date of shipment from J&A USA facility.

**Shipping Costs** - Twenty four (24) month from date of shipment. J&A USA will cover normal shipping costs associated with replacement parts. Expedited shipping cost will incur an additional charge.

**Labor** - Twelve (12) month from date of shipping, J&A USA Inc will cover reasonable labor costs associated with the installation of replacement parts found to be defective in material or workmanship upon inspection by authorized representative of J&A USA INC.

**No labor cost or replacement parts will be covered under this limited warranty if at the sole discretion of J&A USA INC. it is determined a failure was caused by negligence, accident or improper use, improper installation or lack of proper maintenance as in the Owner's Manual.**

**NO CONSEQUENTIAL, INCIDENTAL, CONTINGENT, INDIRECT, SPECIAL OR OTHER DAMAGES WILL BE ALLOWED.** This warranty is null and void if the pedicure spa is removed from its original installation or is not installed accordance with specifications of pedicure spa or national, state or local codes, regulation and ordinances. Furthermore, this limited warranty is null and void if the pedicure spa is subjected to improper installation or maintenance, negligence, improper cleaning or any other circumstance beyond J&A's control. To validate limited warranty, pedicure spa must be installed by a licensed plumber and/or electrician in accordance with local and / or State code and pedicure spa installation instructions.

### **Warranty Exclusion**

- 1- Unauthorized repairs and/or modification or tampered in any way.
- 2- Damage due to freight, accident, natural disaster and /or abuse or misuse
- 3- Stain, fading or discoloration of seat, back cover, armrests ( Upholsteries), Tray or Footrest
- 4- Fading, discoloration or staining of basin or Any portion of surface of pedicure spa caused by water additive or improper water treatment (such calcium built up) and/or cleaning agents/s
- 5- Damage or malfunction due to improper installation including but not limited to, failure to comply with all national, state and local plumbing, electrical and building codes.
- 6- Magnetic jet assembly (base, impeller and cover) due to J&A provided an extra jet assembly to accommodates wear-tear.
- 7- Damage drain pump due to residue built up in drain pipe and / or due to the lack of maintenance.

**Parts for which labor / Service is NOT COVERED** - Following components are simple to replace and DO NOT require a service technician. Therefore, though the part is covered under the guidelines of the warranty agreement.

- 1- Panel
- 2- Jet cover, impeller and / or jet assembly
- 3- Faucet Cartridge, Shower Head
- 4- Footrest
- 5- Air actuate On/Off Button
- 6- Drain Plug
- 7- Remote control

During the Limited Warranty period, J&A will, at its sole discretion, repair or replace any defective component. All component parts removed under this Limited Warranty become property of J&A USA Inc. And all replacement component /s **MUST** be return to J&A USA Inc. within 20 days of replacement. If not, replaced component/s will be charge as its cost/s.

This limited warranty is for the original owner and **not** transferable. The original owner agrees by using pedicure spa the obligation of J&A USA shall not extend to indirect or contingent damage or injury. Furthermore, the obligations of J&A are limited to those set forth herein. The limited warranty is the exclusive remedy and is in lieu of all other warranties, express or limited, including but not limited to, any implied warranty of fitness or merchantability for a particular purpose. No distributor or other person has the right or authority to bind J&A USA INC to changes to this limited warranty. Consequently, J&A USA INC is **not** responsible for such warranties or representations.

### **Limitation of liability**

TO THE EXTENT ALLOWED BY LOCAL LAW, EXCEPT FOR THE OBLIGATIONS SPECIFICALLY SET FORTH IN THIS WARRANTY STATEMENT, IN NO EVENT WILL J&A OR ITS THIRD PARTY SUPPLIERS BE LIABLE FOR ANY DAMAGED CAUSED BY J&A'S PEDICURE SPA OR THE FAILURE OF J&A PEDICURE SPA INCLUDING ANY LOST PROFIT OR SAVINGS, BUSINESS INTERRUPTION, LOSS OF USE OR ANY OTHER COMMERCIAL OR ECONOMIC LOSS OF ANY KIND, OR SPECIAL, INCREMENTAL, OR CONSEQUENTIAL DAMAGES. THIS LIMITATION OF LIABILITY APPLIES WHETHER DAMAGES ARE SOUGHT, OR A CLAIM MADE, UNDER THIS LIMITED WARRANTY OR AS A TORT CLAIM, A CONTRACT CLAIM OR ANY OTHER CLAIM.