

2100 Classic



**Operating Instructions
(120 volt models)**

**Mode d'emploi
(modèles en 120V seulement)**

**Instrucciones de funcionamiento
(sólo los modelos de 120v)**

**Instruções para Utilização
(apenas para os modelos de 120V)**



Model 210006

Model 210007

CONTENTS

- P3 - Decals, displays and controls
- P4 - Introduction.
 - Key to Pictures.
 - Getting Started.
- P6 - Continued Operation.
- P7 - Troubleshooting.
- P8 - Model Information.
- P9 - Additional Information.

TABLE DES MATIÈRES

- p3 - Symboles, affichages et commandes
- p10 - Introduction, touches et mise en marche
- p12 - Fonctionnement continu
- p13 - Pannes
- p14 - Informations
- p15 - Informations supplémentaires

CONTENIDO

- p3 - Calcomanías, pantallas y controles
- p16 - Introducción, claves e iniciación
- p18 - Funcionamiento continuo
- p19 - Localización de averías
- p20 - Información del modelo
- p21 - Información adicional

ÍNDICE

- p3 - Decalcomanias, Luzes Indicadoras e Controlos
- p22 - Introdução, Chave e Como Começar
- p24 - Operação continuada
- p25 - Resolução de problemas
- p26 - Informações sobre o modelo
- p27 - Informações adicionais

2100 Classic

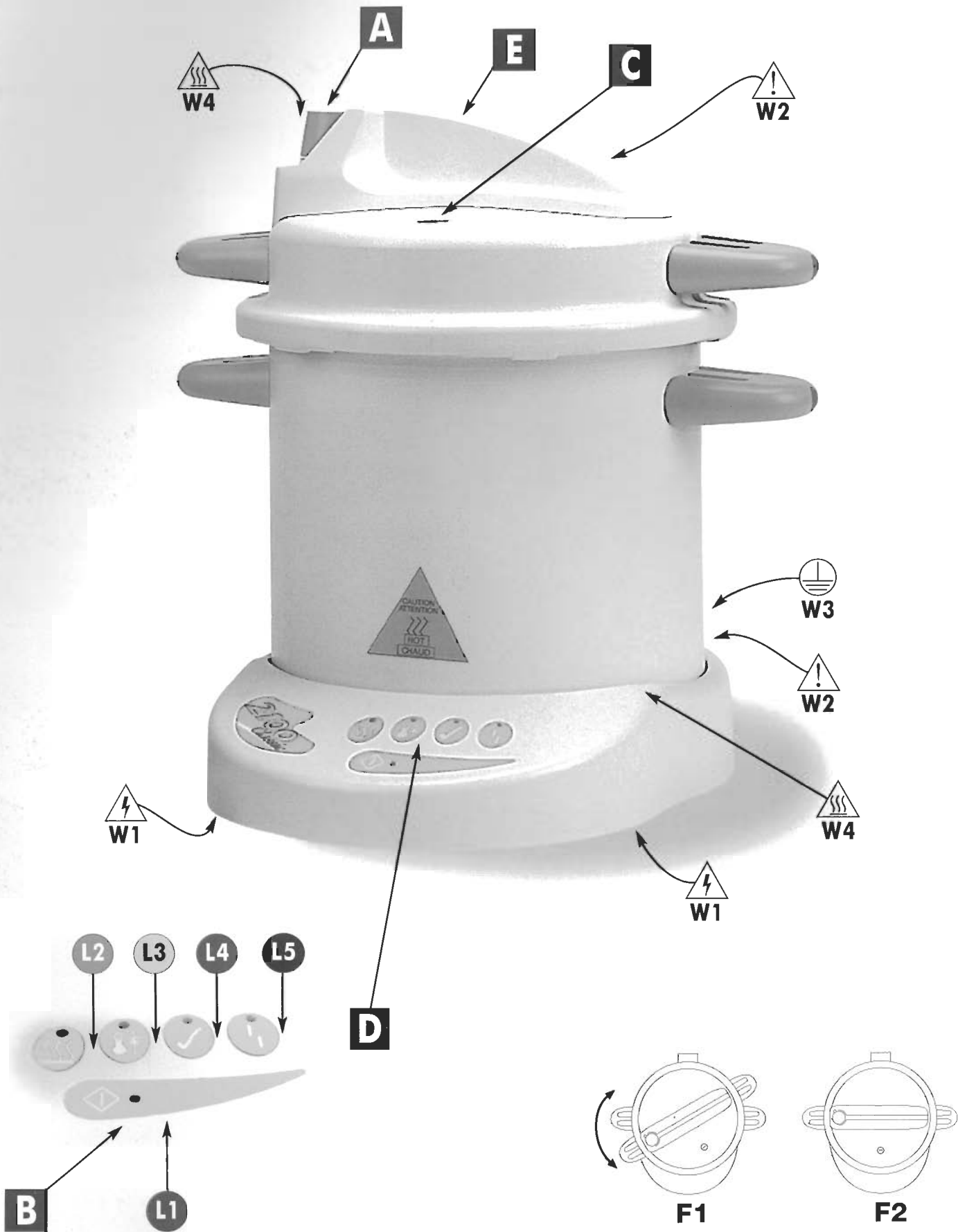

Introduction

Thank you for choosing the Prestige Medical **Series 2100 Classic** Autoclave designed to sterilize solid, unwrapped instruments in a 121°C saturated steam process. After removing from the box, please check for any transit damage. If any damage to the unit is found, please contact your supplier immediately.

Key to Pictures, Displays and Symbols

The following descriptions refer to the pictures of the controls, display lights and operating symbols on Page 3 of this manual.

Controls:

- A** - Depressurization Valve
- B** - Start Cycle Button
- C** - Pressure Rise Indicator
- D** - Display Panel
- E** - WARNING!

The top moulding is not a handle - do not use to remove the lid or lift the autoclave - use the side handles.

HOT PARTS! - Do Not Touch the top moulding during and after a cycle.

Figures:

- F1** - Lid aligned with body, turn clockwise to close
- F2** - Lid in closed position

Display Lights:

- L1** - Power "On" light - illuminates GREEN
- L2** - Heating Light - illuminates ORANGE
- L3** - Sterilizing light - illuminates YELLOW
- L4** - Sterilizing complete light - illuminates GREEN
- L5** - Fault light - illuminates RED

Warning Symbols:

- W1** - Caution, electric shock hazard
- W2** - Warning, read manual before using the autoclave
- W3** - Warning, unit must be earthed/grounded
- W4** - Warning, heat hazard

WARNING!

Do not touch body or lid as these parts become hot when the autoclave is in operation

Getting Started

Before using the autoclave for the first time please take time to read the following pages to familiarise yourself with the operation of the unit. We strongly recommend that all users of the autoclave are trained in its operation. The autoclave is very easy to use. By following this simple operating sequence in conjunction with the pictures of the autoclave, its controls, display panel and operating symbols (page 3), you will be able to ensure your instruments are correctly sterilized every time.

WARNING!

Mains outlet MUST BE GROUNDED (EARTHED)
The mains plug should always be easily accessible as it is to be relied upon as "the means of disconnection"

WARNING!

Models 210006 and 210007 can reach a maximum chamber temperature of 124°C
The manufacturers of instruments should be consulted about their suitability for autoclaving and the maximum temperature which the instruments can withstand.

1. Water

Fill the unit to the water level line on the inside of the chamber with 0.75 litres of **distilled or de-ionised** water.

DO NOT USE TAP WATER OR OVERFILL.

2. Loading (Solid Instruments)

Do not attempt to sterilize lumened instruments or dental handpieces in the unit.

- a) Prior to sterilization, all instruments must be thoroughly cleaned and inspected to ensure they are not damaged and will function properly.
- b) Place UNWRAPPED and WASHED instruments ONLY, plus

a Chemical Indicator Strip, into a suitable instrument container, eg. basket or cassette. (Baskets and cassettes are perforated to permit rapid and complete steam penetration.)

- c) Place all instruments in the vertical, open, unlocked position, ensuring face-to-face contact between flat surfaces is avoided.
- d) Smaller instruments, which can be laid horizontally within the instrument container, should be placed in such a way that all surfaces will be exposed to steam.

NOTE: Point to point contact will not impede sterilization, but significant contact between flat surfaces will.

- e) Instruments which can be disassembled should be, in order to facilitate both cleaning and sterilization.
- f) Before placing the basket in the vessel, place the metal "V" support in the bottom of the unit, to ensure the instruments and the Chemical Indicator Strip are not in the water.
- g) A Chemical Indicator Strip should be placed as near to the centre of the chamber as possible, amongst the instruments.

NOTE: This sterilizer has not been evaluated for use with dental handpieces. Instruments sterilized in this unit cannot be maintained in a sterile state after sterilization because they are unwrapped.

3. Closing.



Always place the lid on the autoclave with the Depressurization Valve (A) open.

Align the lid and body (F1) and turn in a clockwise direction ensuring the lid is completely closed (F2).

Close the Depressurization Valve (A) so it is aligned with the "O" on the lid. **Never leave in position as shown in F1.**

4. Power Connection.

Attach the cable supplied to the rear of the unit and plug into an GROUNDED (EARTHED) mains electrical socket of the CORRECT voltage.

Lights: L1 illuminates GREEN

5. Starting.

Start the sterilizing cycle by pressing button (B)

Lights: L1 illuminates GREEN

L2 illuminates ORANGE

- as the temperature rises, air will be displaced by steam through the Air Bleed Device located in the lid, until it closes with an audible "click", sealing the unit.

The Pressure Indicator (C) will rise indicating the unit is now pressurised.

- 'Sterilizing Temperature' is reached when:

Lights: L1 illuminates GREEN

L2 flashes ORANGE

L3 illuminates YELLOW

- the sterilizing cycle is completed when:

The Buzzer sounds.

Lights: L1 illuminates GREEN

L4 illuminates GREEN

Note: L4 remains GREEN until a new cycle is started or the unit is disconnected from the mains power.

6. Depressurizing.

Once the Sterilizing Cycle has been completed, the unit needs to be depressurized and allowed to cool down before the lid and sterilized instruments can be removed.

The time taken to reach the point at which this is safe to do so can be shortened by **Manually Depressurizing** the unit.

Open the Depressurization Valve (A) by turning slowly in an anti clockwise direction*.

The Pressure Indicator (C) will drop once the steam has been released.

* **Warning:** There will be a visual and audible release of steam from the rear of the top moulding.

7. Unlocking.

Once the pressure has been released the lid may be unlocked. Ensure the Depressurization Valve (A) is open. Remove the lid by turning in an anti-clockwise direction (F1).

8. Unloading

Lift off the lid using the side handles, gently place upside down on a solid work surface and leave to cool. Ensure the Depressurization Valve (A) is in the closed position to avoid damaging it.

The unit has completed a successful cycle if the "spot" on the Chemical Indicator Strip has completely changed colour from yellow to purple.*

The container with the sterilized instruments can now be lifted out of the unit.

To avoid damage, replace the lid as described in step "3"

* **Please Note:** If the "spot" has not completely changed colour, replace with a new Chemical Indicator strip and start a new cycle. If the "spot" fails to change color for a second time, **do not use** the unit until it has been checked by a qualified engineer.

DO NOT USE THE INSTRUMENTS IF A COMPLETE STERILIZATION CYCLE HAS NOT BEEN ACHIEVED.

9. Biological Monitoring

9.1 Selecting Biological Indicator

Healthcare personnel should select Biological Indicators consisting of spores of Bacillus Stearothermophilus that comply with the American National Standard, Biological Indicators for saturated steam sterilization processes in healthcare facilities (AAMI, 1986). In addition, data should be obtained from manufacturers on the reliability, safety and performance characteristics of their products. Manufacturers of Biological Indicators should also be required to provide written instructions on the storage, handling, use and microbiological testing of their products.

9.2 Frequency of Use of Biological Indicators

Table top sterilizers should be biologically monitored during installation and after any major repairs. In addition, sterilization loads should be biologically monitored at least once a week, but preferably daily. Each load containing implantable devices should be monitored and, whenever possible, the implantable devices should be quarantined until the results of the Biological Indicator testing are available. Biological Indicator should also be used for periodic monitoring of all types of packages and trays processed.

9.3 Biological Indicators

This sterilizer is designed for surface sterilization, therefore, a spore strip or self-contained Biological Indicator offers an appropriate challenge to measure delivery of an adequate dose to kill spores. Placement of Biological Indicators should be near the centre of the instrument load in the basket or in one of the cassettes. For small loads, the indicator should be placed amongst the instruments which are being processed.

9.4 Routine Biological Monitoring

For routine biological monitoring, the sterility of the load is evidenced by the killing (failure to recover) of all spores on the test Biological Indicators (spore strips). All Biological Indicator results, including results from controls, must be interpreted by a qualified individual and must be included in the sterilizer records.

Continued Operation

To ensure your autoclave gives you the years of service for which it was designed, it is important to remember a few "do's" and "don't's" with regards to the operation of the unit and to carry out the simple care and maintenance procedures on a weekly basis.

Do ensure that....

- 1.... you read these instructions and always follow the operating sequence.
- 2.... the work surface on which you will place the autoclave is flat, solid and level.
- 3.... the instruments are designed to withstand the sterilizing temperatures selected, are thoroughly cleaned and rinsed before sterilizing, and are not any longer than the length, or exceed the load weight, specified - see "Technical data" section.
- 4.... the water level is maintained regularly with clean distilled or de-ionised water only.
- 5.... the unit is in a "draught free" environment and is positioned not less than 250mm from adjacent walls.
- 6.... you only use green sealing gasket (219500) and that it is changed at the end of it's life, if visibly damaged, or when shrinkage has occurred, see "Fault mode - 5".
- 7.... the lid is securely closed when the unit is not in use, to avoid the risk of accidental damage.
Never leave in position as shown in F1.
- 8.... you quote your model details, serial number and date of purchase when contacting Prestige Medical or your supplier.

Do not....

- 1.... touch the unit whilst in operation - it gets HOT.
- 2.... attempt to remove the lid during operation.
- 3.... lose this operating instruction manual
- 4.... add any chemicals whatsoever to the water.
- 5.... attempt to sterilize volatile substances toxic materials or inappropriate loads.
- 6.... place the unit on heat sensitive surfaces ie. polished wood or glass.
- 7.... open the Depressurization Valve (A) during the sterilization cycle.
- 8.... leave the Depressurization Valve (A) in the "open" position when placing the lid upside down on a work surface.
- 9.... immerse the unit or electrical cord in water when cleaning.
- 10.. use abrasive materials or lubricants when cleaning.

- 11.. drop or abuse the unit.
- 12.. use in areas of risk associated with flammable materials or gasses.
- 13.. attempt to change fuses until the unit has been unplugged from the mains. Only qualified persons should change fuses.
- 14.. reach over the unit when removing cover, to do so may cause burns from rising heat and steam.
- 15.. press start button once cycle has been started as this will re-set the cycle timer to zero.

Care and Maintenance.

WARNING!

Disconnect the autoclave from the mains power supply before cleaning.

Green Sealing Gasket.

1. Remove from inside the lid and clean with warm, soapy water.
 2. Rinse thoroughly, shake dry, do not wipe.
 3. Replace in the lid by tucking evenly under all lugs starting at the Gasket Offset Device. It may appear slightly wrinkled until used.
 4. Replace gasket when it begins to show signs of leakage.
- Autoclave.
6. If a new gasket leaks, or a persistent leak develops, gently clean the sealing surface of both the lid and body of the unit with a plastic "Scotchbrite" scrubbing pad making sure you do not remove any metal. Rinse both surfaces but do not dry.
 7. Clean both interior and exterior with warm, soapy water ensuring the electrical parts are kept dry.
 8. Monitor the first cycle of the day to check the Air Bleed Device, which is located inside the lid, audibly "clicks" shut.
 9. Prestige Medical recommend that your unit is calibrated at six monthly intervals.
 10. Lubricate underside of body lugs with "vaseline" if the lid becomes stiff.
DO NOT LUBRICATE GASKET

Troubleshooting

In the event of a fault occurring during any stage of the units operation, identify the fault by referring to the descriptions below. The fault can be rectified by following the Fault Remedy applicable to the problem incurred.

Fault Indication/Description/Remedy

Fault 1: No Power to Unit

Light: **L1** fails to illuminate.

Check for defective socket.
Check for power to socket.
Ensure lead is connected to electrical socket

Fault 2: Low water or Boil dry.

Light: **L5** flashes RED

Allow unit to cool before refilling to the correct level.
Disconnect from mains then reconnect and repeat cycle.
If the fault repeats with sufficient water, arrange for a service engineer to visit.

Fault 3: Sterilization failed to be achieved.

Light: **L4** fails to illuminate GREEN and there is no audible buzzer

Disconnect from mains then reconnect and repeat cycle.
If the fault repeats arrange for a service engineer to visit.

Fault 4: Incomplete Sterilization cycle

TST strip fails to change / completely change colour.

Check expiry date of TST strips.
Disconnect from mains then reconnect and repeat cycle.
If the fault repeats arrange for a service engineer to visit.

Fault 5: Steam or water leaks from under the lid

i) Worn or dirty gasket.

Wash gasket and sealing surfaces on the body and lid as described under "Care and Maintenance".

If the fault persists, replace with a new gasket.

ii) Incorrectly closed lid.

Ensure the unit is fully depressurized by opening Depressurization Valve **(A)**.
Remove lid and re-fit carefully.
Disconnect from mains, reconnect and repeat cycle.

Fault 6: Excessive steam or water leaking from Depressurization Valve **(A)**.

Depressurization Valve **(A)** in "OPEN" position.

Close Depressurization Valve **(A)**.

Model Information

In the unlikely event that something should go wrong, we have incorporated a number of safety features to ensure that your autoclave remains safe at all times.

Safety features.

1. Located to the rear of the lid, beneath the cover, is a spring called the Gasket Offset Device (GOD Spring), designed to prevent pressure building up if the lid has been incorrectly fitted.
DO NOT TAMPER WITH THIS SAFETY DEVICE
2. If for any reason, the temperature falls below the minimum required sterilizing temperature, resulting in the Sterilizing light (L3) switching off, the cycle timer will re-start from zero once the correct temperature has been restored.
3. If there is an electrical or electronic failure resulting in a build up of pressure - in excess of normal operating pressure - one or all of the following safety features will be activated.

- i) Depressurization Valve (A) will loudly and rapidly "vent" steam.
- ii) The gasket will "extrude" through the slot in the rear of the lid rapidly releasing excess pressure and steam.
- iii) A non - resettable thermal fuse located in the base of the unit will "melt" at a pre-determined temperature, disconnecting the power.



Should any of the devices listed above activate, please observe the following steps:

- a) Do not touch the unit.
- b) Switch off at the wall socket and un-plug
- c) Allow temperature and pressure to drop before i) touching the unit
ii) removing your instruments
- d) Do not attempt to re-start the unit
- e) Arrange for an immediate service.

Technical Specifications - Standard Body Autoclaves - Model 210006

Height335 mm (13.19")
 Width340 mm (13.39")
 Net Weight4.5 kgs (9.92lb)
 Capacity9 litres

Internal Dimensions (d/h)210/230 mm (8.27/9.06")
 Max' Instrument Length228mm (8.98")
 Max' Load Weight3.0kgs (6.62lb)

Technical Specifications - Extended Body Autoclaves - Model 210007

Height420 mm (16.54")
 Width340 mm (13.39")
 Net Weight4.5 kgs (9.92lb)
 Capacity12 litres

Internal Dimensions (d/h)210/270 mm
 (8.27/10.63")
 Maximum Instrument Length290 mm (11.42")
 Maximum Load Weight.....4.0 kgs (8.82lb)

Temperature 121°C - 124°C
 Sterilizing time 18 mins

Volts 120v
 Watts 1200 watts
 Frequency 50 - 60 Hz

Rating - Models are rated continuously for intermittent use.

Pollution Degree - Group 2

Body - Deep drawn aluminium.

Environment Conditions - indoor use - temperature 5°C to 40°C - altitude up to 2000m - maximum relative humidity 80% for temperatures up to 31°C decreasing linearly to 50% relative humidity at 40°C. - mains supply voltage fluctuations not to exceed +10% of the nominal voltage

Lid - Drawn aluminium.

Heater - Externally surface mounted mechanically fixed electric element.

Input Connections - Mains inlet socket 'hot' format conforming to IEC 302.

Temperature Cut Out - Thermal fuse.

Safety Shut Down - See 'Temperature Cut Out'.

Pressure - Calibrated pressure release valve.

Max. Single Fault Temperature - 133.3°C

Packaging - All packaging materials are recyclable.

Over Voltage Category - Group II

Spares

Only those spare parts supplied or specified by Prestige Medical should be used in the maintenance of the autoclave. Use of unauthorised parts will invalidate any warranty given and may adversely affect the performance and safety of the unit.

Accessories

A range of accessories are available for your autoclave as described below and pictured on page 28. Contact your supplier for full details.

- | | |
|---|---|
| 1 - 219294 - Lifting Device | 6 - 219290 - Cassette Rack |
| 2 - 219293 - General Instrument Tray | 7 - 219296 - Extended Basket (210007 Only) |
| 3 - 219292 - Standard Basket | 8 - 219500 - Green Silicone Sealing Gasket |
| 4 - 219295 - 'V' Support | 9 - 219277 - Chemical Indicator strips |
| 5 - 219291 - Cassette Box | 10 - 219299 - Cord Set UL |

Warranty

Prestige Medical shall, in the first 12 months from the date of purchase, repair or replace free of charge any parts which prove to be defective in workmanship and/or materials. The heating element (only) is covered by a **lifetime guarantee**.

Prestige Medical shall not be so liable in the event that the purchaser has failed to adhere to the instructions contained herein or if the autoclave has been abused, interfered with, altered, repaired or serviced by any unauthorised party this may also result in the protection provided by the equipment being impaired.

This warranty excludes the gasket, all internal furniture and consumables.

Consumer's statutory rights are not affected.

Product decontamination.

Should the unit require repair, it must be decontaminated in accordance with a recognised procedure prior to return or on-site repair. A statement of equipment contamination status must be available with the product. (Details of a suitable procedure are available on request).

Cleaning materials:

- Mild washing up liquid.
- Non-abrasive cream cleaner.
- Warm water

Approvals.

Products are UL and CSA approved.

Packaging

All Prestige Medical packaging materials used are recyclable - please dispose of accordingly.

PLEASE NOTE: English is the original language for the purposes of these instructions. All other languages are translations from the English text.