

Assembly Instructions

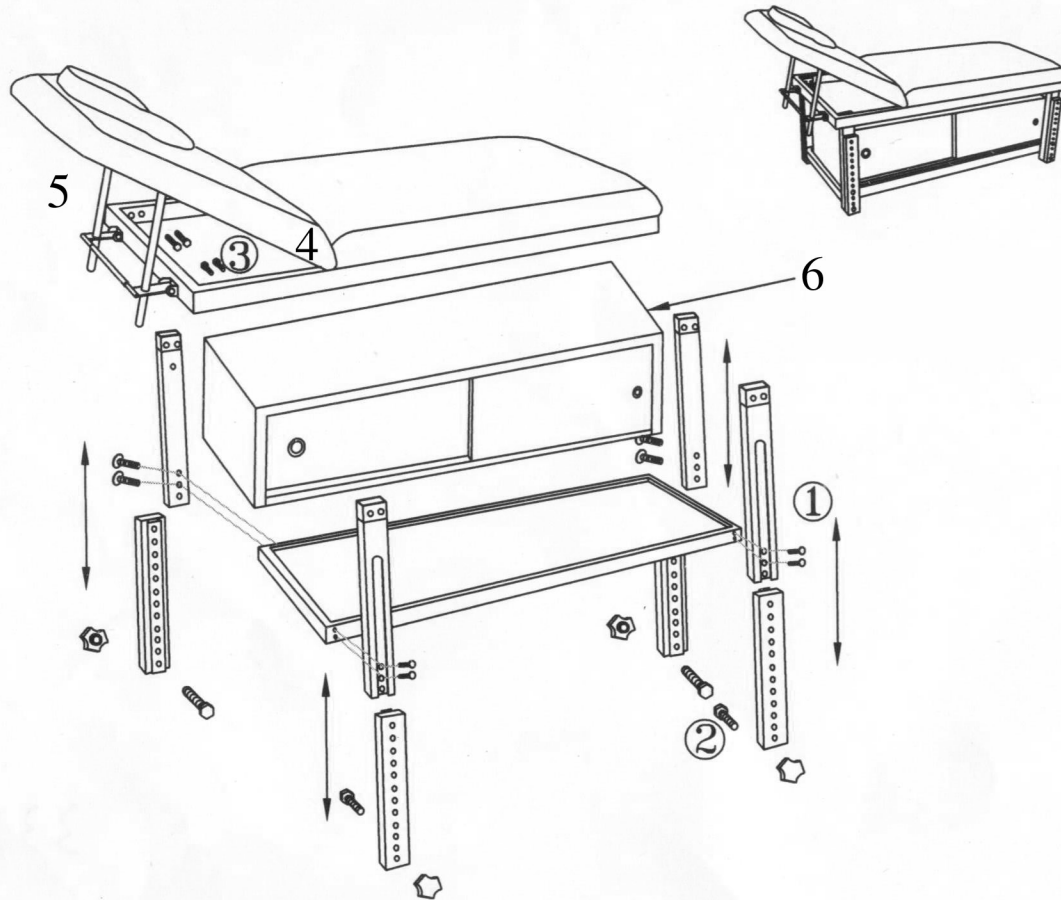

1. Remove the screws from the legs and screw them into the wooden bottom.
2. Adjust the height of the outer leg and screw the big screws into the legs.
3. Attach the top part of the bed to the metal frame with screws.
4. Screw the top of the legs into the metal frame of the bed.
5. Screw the 2 metal poles to the bottom of the upper part of the bed.
6. Place the cabinet from either side of the bed.