

MADE  
IN THE **USA**

## Product Description:

- Kit Includes:
  - BW004-0512 Bottle Holder - 1 Gallon
    - Holds one gallon of hand sanitizer
    - Quartz Beige Powder-Coated Aluminum
  - KS010-0412 Floor Stand
    - Quartz Beige Powder-Coated Steel
- Assembly hardware included

## Primary Area for Product Usage:

- All ports of entry
- Anywhere respiratory hygiene products are needed

## Dispenses:

- Bottles no larger than 13.00"H x 6.50" diameter (16.5 cm x 8.82 cm)

## Product Specifications (overall assembled dimensions):

- 17.00"W x 41.51"H x 17.00"D (43.2 cm x 105.4 cm x 43.2 cm)
- 15.2 lbs (6.9 kg) - approximated

## Package Specifications:

- Package Quantity: 1 per case
- 36"L x 20"W x 6"H (91.4 cm x 50.8 cm x 15.2 cm)
- 18.0 lbs (8.2 kg) - approximated



Sanitizer bottle and pump not included

## Assembly

Always mount dispensers securely *prior* to loading with product.

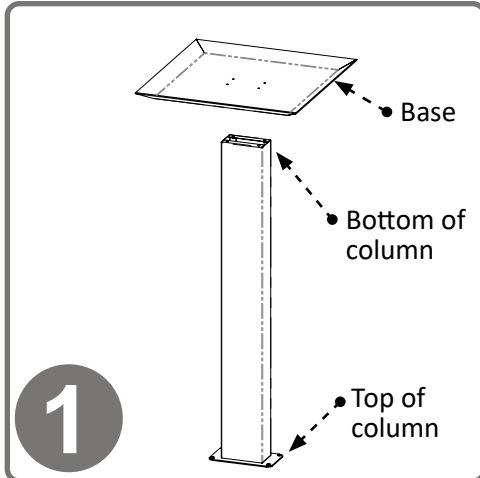

To secure base to column, turn column upside down (with top plate down) and place base inverted, as shown, on column.

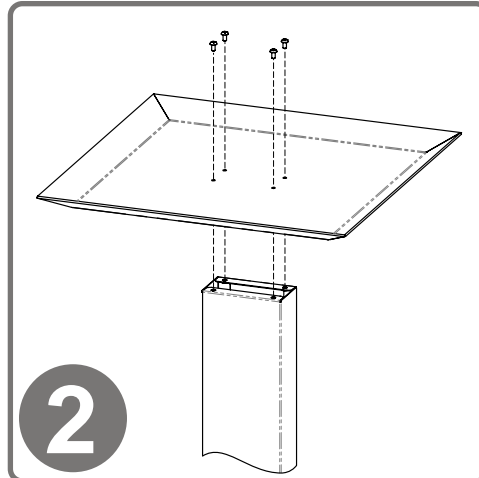

Use Phillips screwdriver to secure base to column with (4x) screws (10-32 x 5/16").

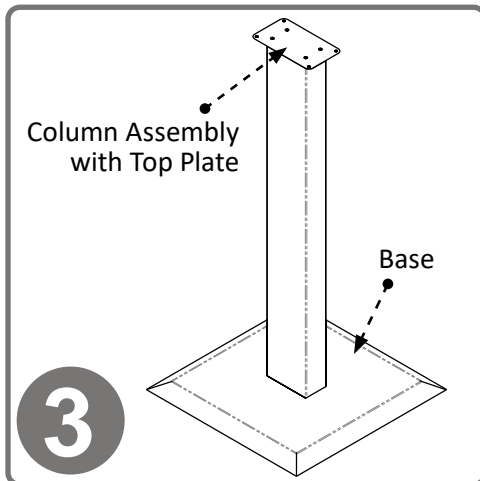

Turn stand right side up, so the base is on the floor.

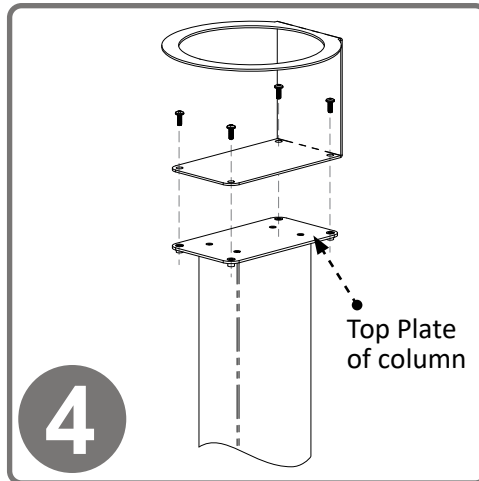

Attach the BW004-0512 Bottle Holder to the column using (4x) screws included with stand. Tighten.

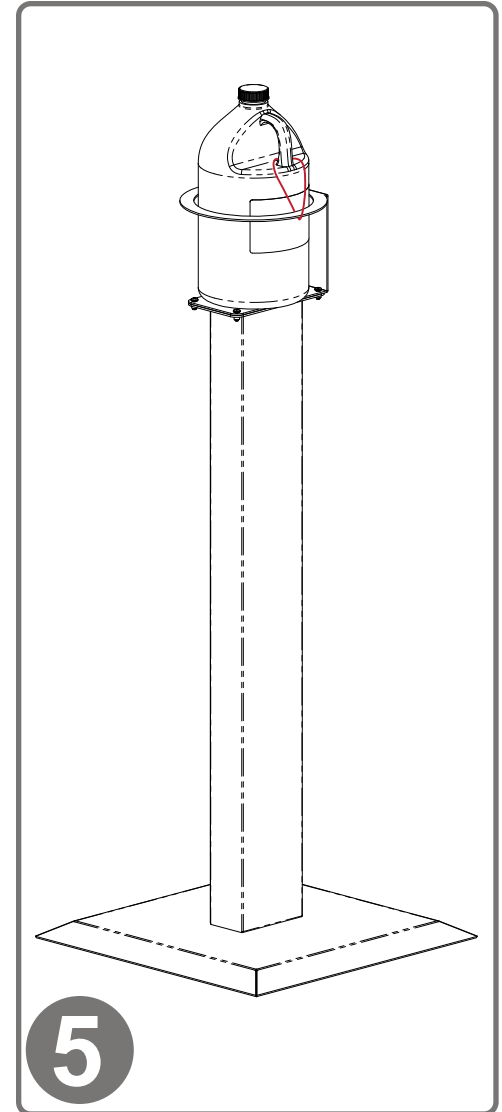

Bottles can be secured with a zip-tie or cable from the handle to the top ring, if added security is needed.

### Parts included:

- Base
- Column
- Bottle Holder - 1 Gallon
- Hardware
  - (8x) 10-32 x 5/16" Phillips head screws

### Tools Required:

- Phillips Screwdriver
- Flathead Screwdriver

## BW004-0512

Powder-Coated Aluminum

## KS010-0412

Powder-Coated Steel

### Material Characteristics

#### Designed for Long-Term Use

Our powder-coated aluminum dispensers resist corrosion, chipping, and flaking. It is lightweight, yet high in strength. This material will provide long-lasting products that hold up well, even in tough environments.

Powder-coated aluminum is ideal for dispensers used in a healthcare or industrial settings. It is impact resistant and is not affected by extremes in temperature.

Dispensers made of powder-coated aluminum are clean, bright, and attractive, creating a professional appearance.

#### Designed for Long-Term Use

Our steel dispensers and stands are coated with polyester powders which makes them highly resistant to corrosion.

Powder-coated steel is ideal for dispensers used in a healthcare or an industrial setting because it is impact resistant and is not affected by extremes in temperature.

Dispensers and stands made of powder-coated steel are both attractive and functional, providing years of service.

### Care and Cleaning

For best results, clean by washing the surface with a diluted solution of a mild, non-abrasive detergent in cold or warm water and a non-abrasive cloth. Standard hospital cleaning supplies can be used.

Dry with a soft cloth. Do not use any solvent-based materials, abrasives (e.g. Scotch-brite, steel wool), or apply excessive force during cleaning.