

# INSTRUCTIONS FOR OPERATION AND CARE OF

# Thermalator™

LITTLE

## Therm

Compact Thermalator

Model LT-4

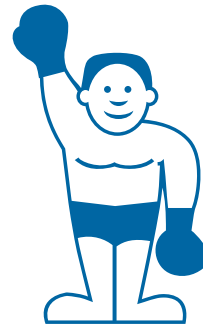

**Whitehall**  
*Manufacturing™*

800-782-7706 • 626-968-6681 • [www.whitehallmfg.com](http://www.whitehallmfg.com)

Whitehall Manufacturing is a Member of Acorn Engineering's Family of Companies.



## TABLE OF CONTENTS

Introduction .....	3
Model Descriptions .....	3
Caution .....	4
Warning .....	4
Danger .....	4
Setting Up .....	5
Filling .....	6
Emptying .....	7
Checking Out My Little Therm .....	8
Using the Thermal Pack .....	8
Using the Wire Rack .....	10
Maintenance .....	11
Cleaning and Sterilizing .....	11
Storage .....	11
Troubleshooting .....	12
Repair of Unit .....	12
Parts Diagram Wiring Assembly .....	13
Parts Diagram Final Assembly .....	14

## Instructions for Operation and Care of Little Therm Compact Thermalator



**Congratulations** on receiving your compact Little Therm Thermalator.

Little Therm is a simple and trouble-free unit to operate. The tank body, bottom and lid are all made from type 304 stainless steel with a thermostat on the rear to control the water temperature. Unit should be set for 160° F for normal operating temperature.

Side handles and a knob on the lid minimize contact with the hot surface. The unit has Thermal Packs with colored tabs and an exposed heating element with a concealed temperature sensor.

Unit rating is 120V, 8.3A, 50/60 Hz.

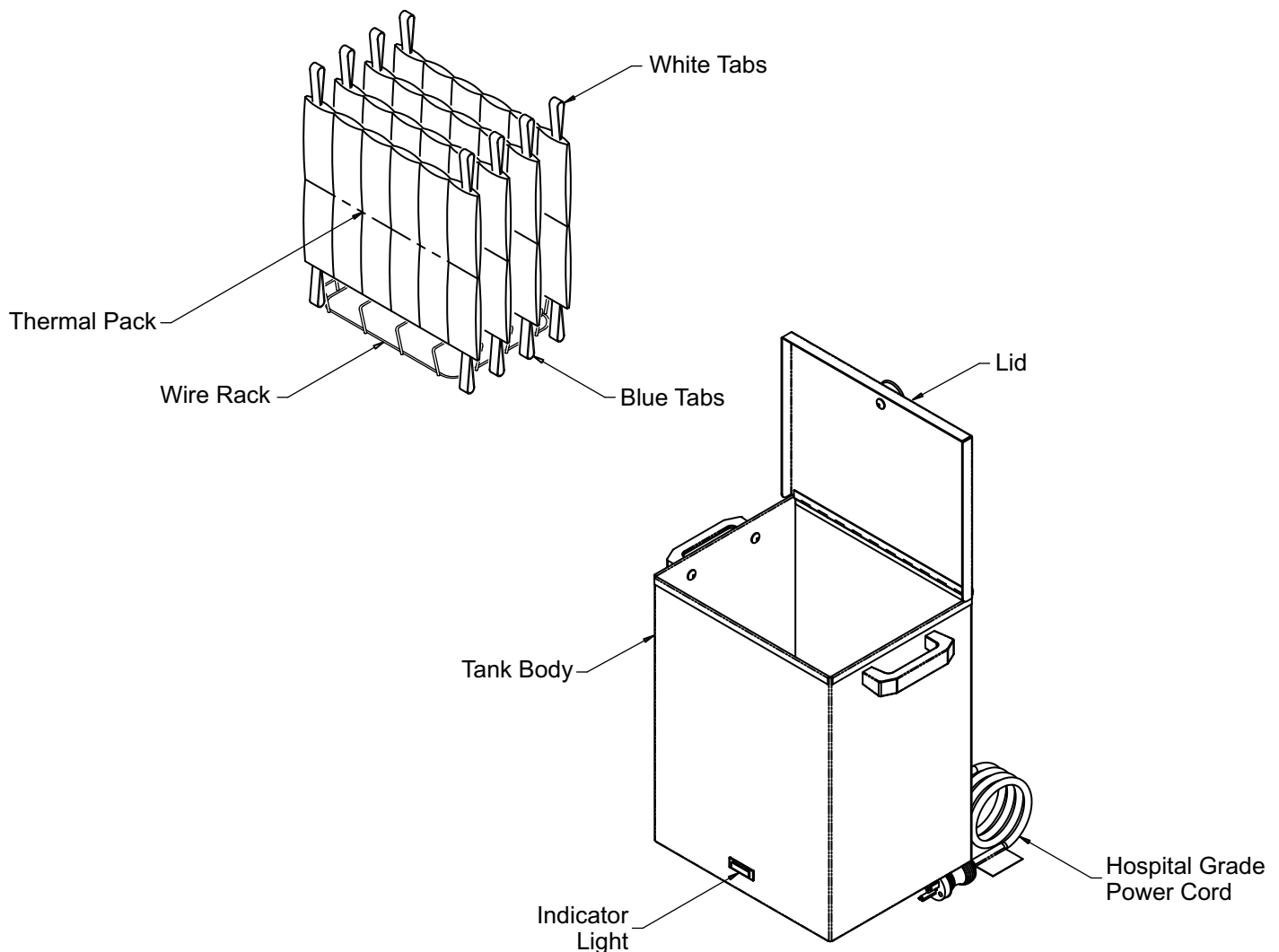



## Instructions for Operation and Care of Little Therm Compact Thermalator

The instructions below are indicated by specific symbols. An understanding of these symbols, their companion text and the specific instructions and captions must be understood prior to operation of the equipment and patient treatment.



**CAUTION-** Ignoring the following could cause injury or equipment damage.



**WARNING-** These are safety infractions that could result in serious injury.

**DANGER-** These are possible safety infractions if this equipment is used where flammable anesthetics are present.



### **CAUTION**

- All internal parts capable of transmitting electric current are grounded. Therefore, the electrical outlet to which the unit is attached must be properly grounded. Grounding reliability can only be achieved when the equipment is connected to an equivalent receptacle marked "Hospital Only" or "Hospital Grade". If there is any question as to the electrical protection, a qualified electrician should be consulted.
- The table or cart must be level for proper and safe use.
- Little Therm Compact Splint Pans are intended for use only where the person utilizing the treatment is under the supervision of trained personnel.
- **DO NOT** operate the unit dry - always make sure to fill with water before plugging in unit.
- Treatment temperature must be monitored closely and, of course, a patient's medical history must be reviewed, as with any heat modality, for heat sensitivity and circulatory problems.

- Always disconnect the line cord plug from the receptacle before working on any unit.
- Do not use bleach or iodine based products to clean the tank as such products can quickly corrode the stainless steel tank resulting in pin holes and leaking water.
- Do not touch cord or plug if you are wet, standing in water or on a wet surface.
- Constant supervision is necessary when the unit is used with children, invalids, or any one who cannot safely operate the unit.



### **WARNING**

- Do not use the unit outdoors.
- Do not reach into water to get the thermal packs. Use the blue or white tabs or tongs.
- Do not place the Thermal Pack on bare skin. Always place the Thermal Pack in a terry cover.
- Refer service and electrical problems to qualified personnel and/or Whitehall Manufacturing only.
- Do not use if the unit, cord, or plug has been damaged. Return unit to Whitehall Manufacturing or a qualified service center.
- Do not use an electrical extension cord. Plug unit directly into a properly grounded receptacle. If there is any question on the grounding of the receptacle, call an electrician.
- Replace fuse as marked 10A/250VAC fast acting glass tube type.

### **DANGER**

- Do not operate any thermalator where flammable anesthetics are present.



## SETTING UP

1. Your new Little Therm includes the following:

- 1 Little Therm Model LT-4
- 4 Thermal Packs (10" x 12")
- 1 Wire Rack - (stainless steel with vinyl coating)
- 1 Warranty Registration Card
- 1 Instructions for Operation and Care

If you are missing anything, please call the phone number listed on the back page.

### 2. Unpacking your Little Therm

Remove all the shipping material. Remove Thermal Packs and wire rack from inside the tank. Remove all packaging from inside the tank, especially from under the heating element inside the tank. Clean the unit thoroughly before using.

### 3. Device Placement:

Place the Little Therm at a convenient level, such as on a table or a scratch resistant counter top. Before moving the Little Therm, unplug and cool the unit. Only move the unit to empty or fill it. Always use the handles. The unit may be hot to the touch.

### 4. Pre-Soaking Thermal Packs

Before the first use, you must condition each Thermal Pack. Soaking in water lets the pack swell to its full size. This is necessary only BEFORE the first use. You can then reuse the pack after about 15 minutes of reheating.

- 1- Take the Thermal Pack by the corner loops - one white and one blue - so the sections are horizontal.
- 2- Gently shake the pack back and forth to evenly distribute the filler material.

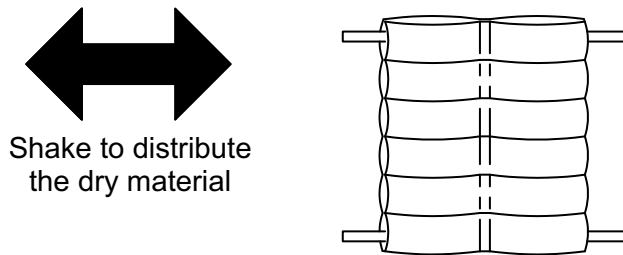

3- Place the Thermal Packs in a large metal pan to pre soak (use stainless steel or enamel-ware, DO NOT use aluminum) or plastic container. You may use the Little Therm for pre soaking.

- Place the Thermal Pack in the unit with sections horizontal.
- Change the water after soaking or water will become cloudy.

- 4- Fill the container with enough tap water to completely cover the Thermal Packs.
- 5- Soak the packs for 1 hour minimum, 2 hours or more is recommended.
- 6- Return the packs to upright position. The packs are now ready for heating.

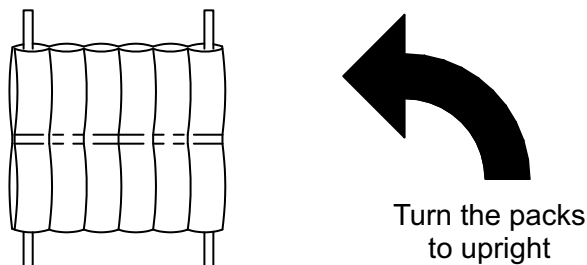



## FILLING

- 1 Make sure the unit is unplugged and all packaging has been removed.

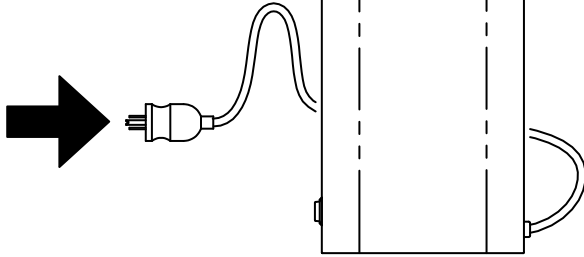

- 2 Fill unit about 3/4 full with tap water.

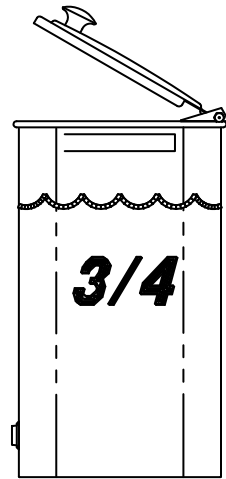

- 3 Place the wire rack inside the unit. Be careful of the heating element.

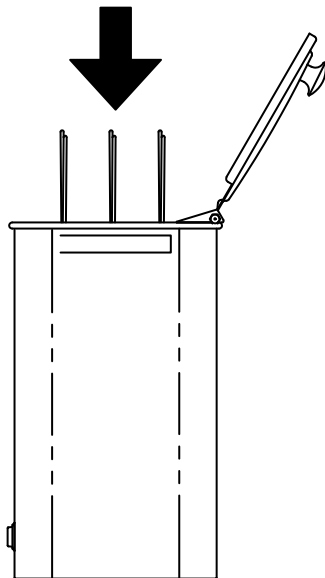

- 4 Put the Pre-Soaked Thermal Packs on the wire rack. Place all the blue or white tabs up.

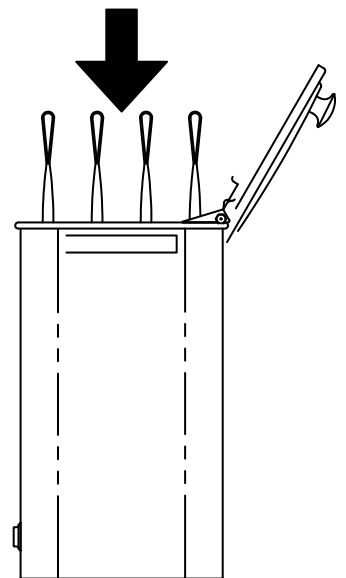

- 5 Add more water, if necessary, to cover the Thermal Packs. Uncovered packs may be damaged during heating.

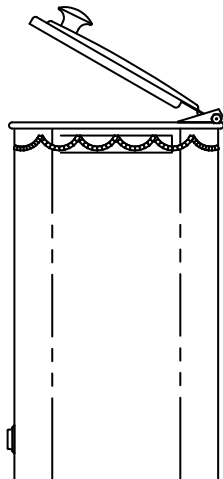

- 6 Close the lid.

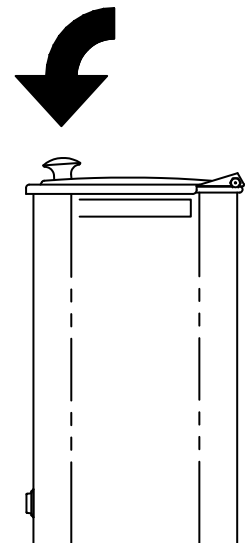



- 7 Plug the power cord into an AC outlet. A Ground Fault Circuit Interrupter is recommended because it will give additional protection from electric shock.

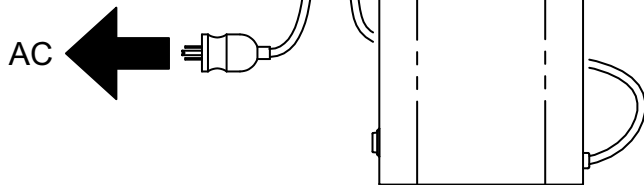

- 8 Indicator light should be illuminated.

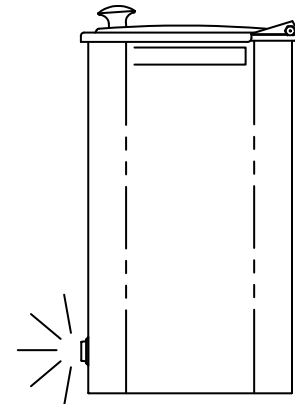

## EMPTYING

- 1 Unplug the unit.

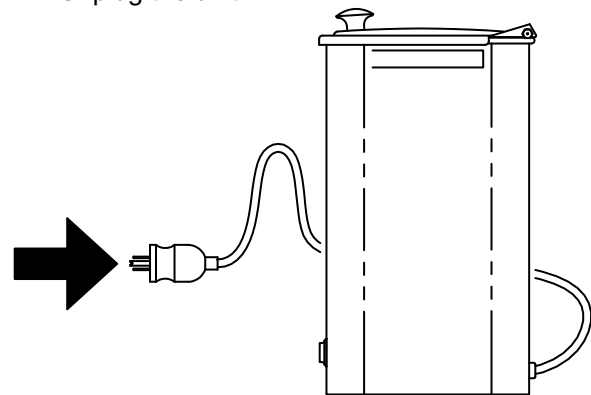

- 2 Let the water cool to room temperature. Remove the Thermal Packs and the wire rack.

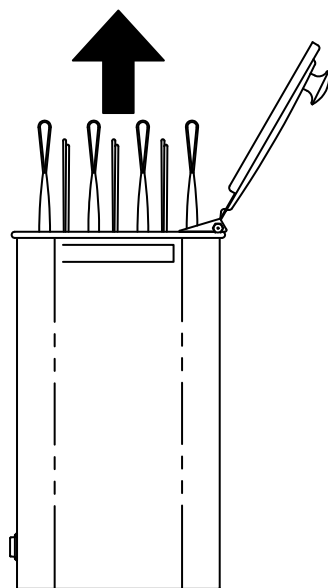

- 3 Pick up the unit by the handles and pour out into a sink or floor drain.

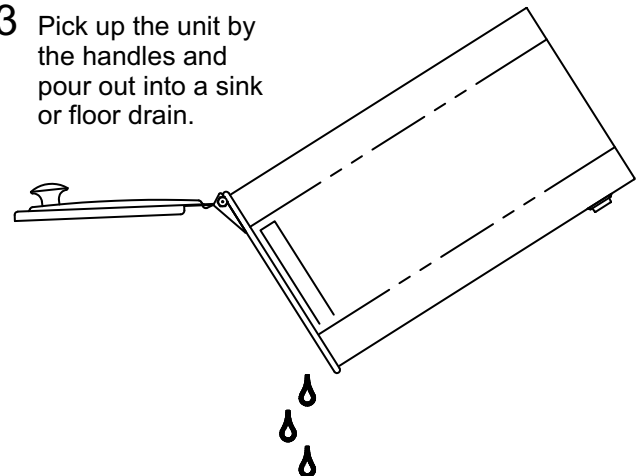



## CHECKING OUT my Little Therm

Before the FIRST use, check the following:

- 1- The Little Therm should be level.
- 2- The Little Therm should be plugged directly into a properly grounded GFCI receptacle. Do not use extension cord. Undersized extension cords can overheat.
- 3- The Little Therm should be in good condition.

Your new Little Therm is now ready for use. If you have any questions about SETTING UP or CHECKING OUT your unit, please call the phone number listed on the back page.

## USING the Thermal Pack

1- For each use:

1 Open the lid.

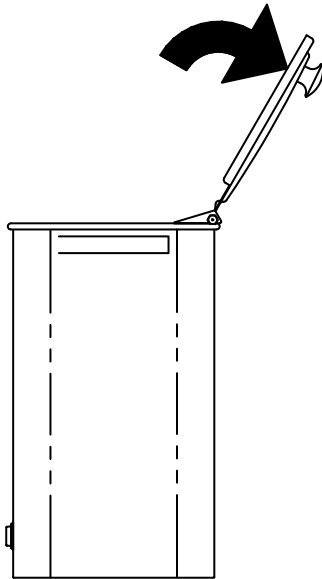

2 Using tongs, carefully remove the Thermal Pack.

Caution: the Thermal Pack can cause skin burns.

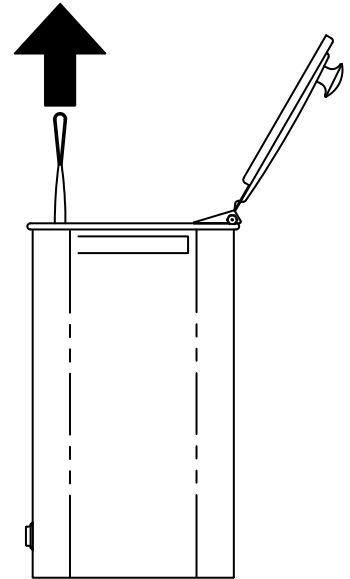

3 Wrap the pack in a Thermal Pack Cover or 5 to 6 layers of terry toweling.

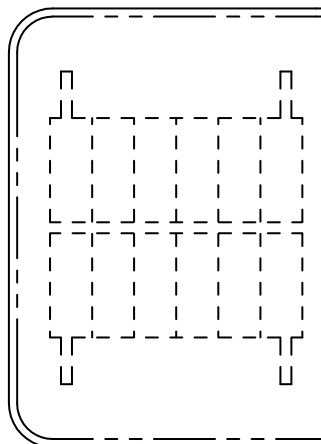

4 Put the wrapped pack on the area to be treated for a pre-set treatment time.

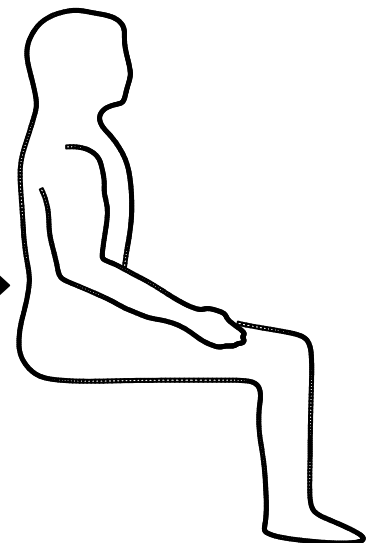
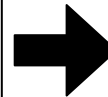
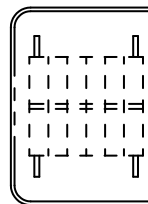





- 5** Remove the Thermal Pack from the patient.

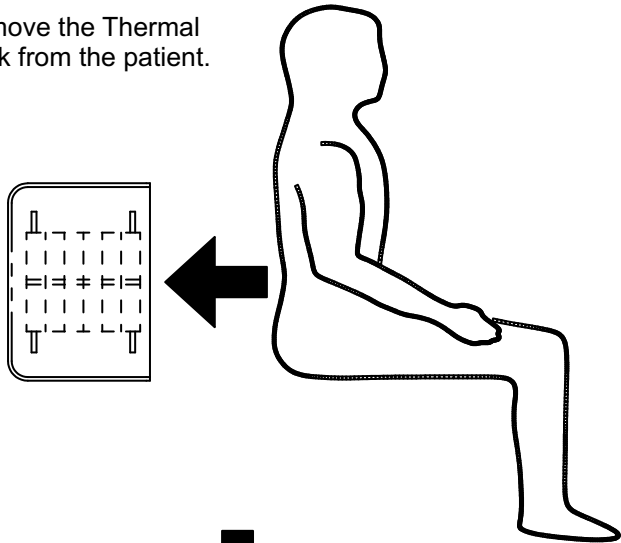

- 6** Remove the Thermal Pack Cover or toweling. Hang to dry or launder.

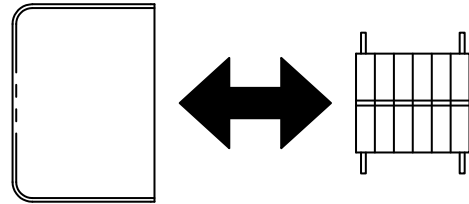

- 7** Open the lid. Return the pack to the Little Therm. If the blue tab was up, put the white tab up now. Work your way from first to last, reversing tabs each time.

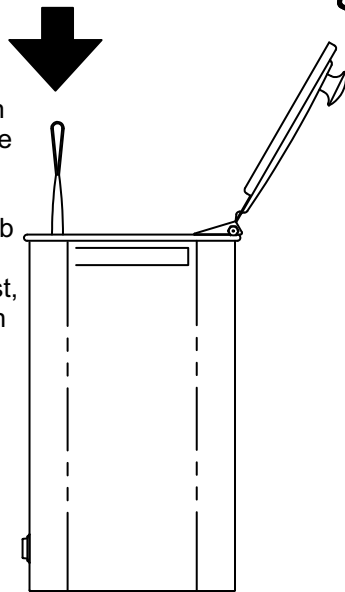

- 8** Close the lid. The Thermal Pack will be reheated within 15 minutes and ready for use.

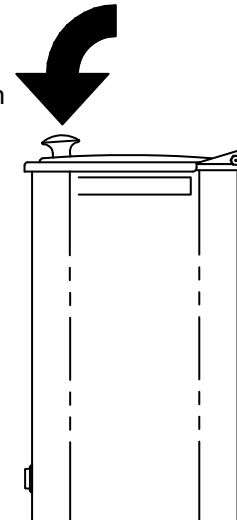

**2- Daily use:**

- 1** Add more water, if necessary, to cover the Thermal Packs. Uncovered packs may be damaged during heating.

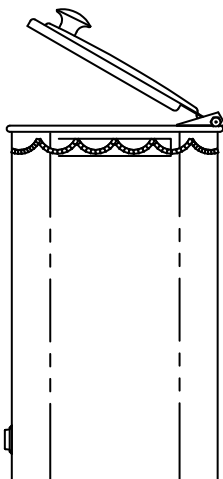

- 2** Place all colored tabs in the same reference (either all up or all down) to start the day.

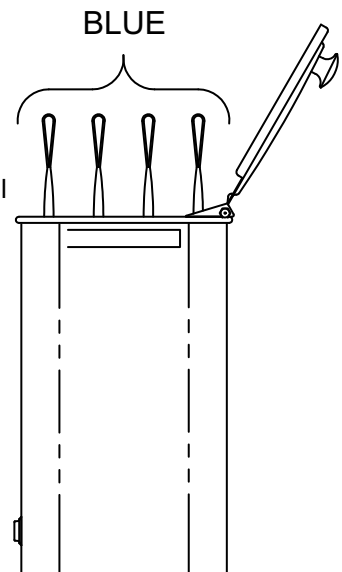



## Instructions for Operation and Care of Little Therm Compact Thermalator

### 3- Periodic use:

The water temperature for normal operating conditions is about 165°F. The thermostat is very sensitive; even a small adjustment can raise or lower the temperature several degrees. To adjust the temperature, you need the following:

- Small, flat blade screwdriver
- Thermometer capable of 190° F

- 5 Facing the back of the unit, find the metal temperature knob between the 2 screws in lower right side of the unit.

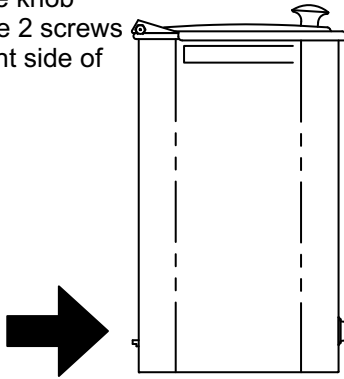

- 6 Using the screwdriver, turn the stem clockwise to increase the temperature. Allow the temperature to stabilize, and measure the water temperature with the thermometer.

**CAUTION:** Sensitive thermostat; a small adjustment changes several degrees.

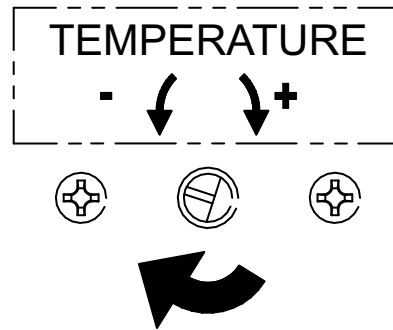

## USING the Wire Rack

Your Little Therm uses many different sizes of Thermal Packs. For Half, Cervical or Myofacia sizes, a small rack adapter is provided. For Standard, Knee/Shoulder, 10" x 18" and 10" x 24" sizes, use only the stainless steel wire rack provided.

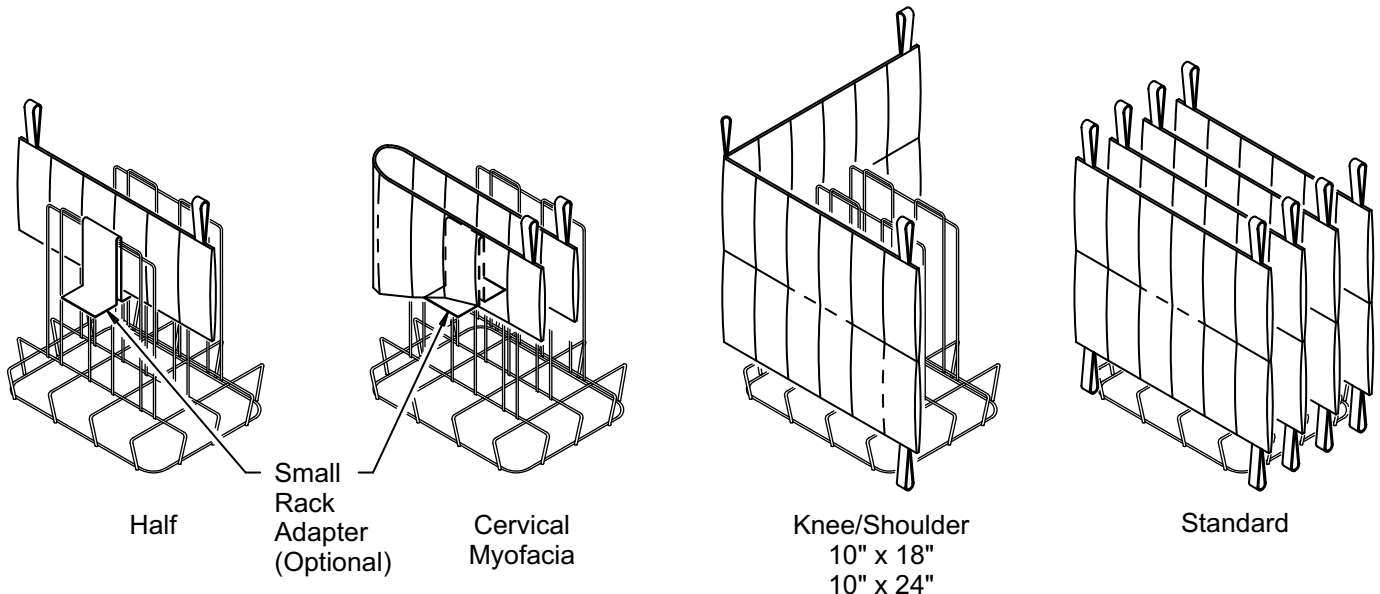



## MAINTENANCE

The Little Therm design is nearly maintenance-free. It should, under most conditions, give many years of reliable service. Clean and replace the Thermal Packs as described below.

### 1. Routine Maintenance (As Needed)

- See Cleaning and Sterilizing
- Always keep the Thermal Packs under water. Replace any water that has evaporated.
- Destroy or discard any contaminated Thermal Packs.

### 2. Monthly Maintenance

- See Cleaning and Sterilizing
- Clean wire rack and insert using mild soap. Rinse thoroughly with clean tap water. Dry with soft cloth.
- Scrub your Thermal Packs with warm soap and water.
- Keep the pH (a measure of acidity of the water) between 7.4 and 7.8 to reduce the scaling and residue build-up.

### 3. Yearly Maintenance

- Replace worn out Thermal Packs. When The packs begin to wear out, the non-toxic filler oozes through the fabric and seams. The individual cells seem empty. These packs don't hold the heat. Throw away worn Thermal Packs.
- Have a professional electrician thoroughly check the following:
  - 1- Test for leakage current, dielectric strength, and receptacle polarity and ground. If you need test need test details, call the number listed on the back page.
  - 2- Check the power cord and plug. They should be free of cuts, abrasion and other damage. Replace the power cord assembly if it is damaged. Use only factory replacement parts.
  - 3- Remove the cover and check all electrical components and connections. Replace any parts that are in questionable condition. Use only factory authorized replacement parts.

## CLEANING AND STERILIZING

Cleaning of the tanks can best be accomplished with a very mild, non-scratching household cleaner and a very low abrasion plastic scouring pad lightly applied. On a stainless steel tank, never use a metal scouring pad as it is too abrasive and may leave carbon metal deposits on the stainless which will rust.

Again, disinfection and sterilizing is different from facility to facility, and we have found that alcohol is still the best (but expensive) cleaning and sterilizing solution. Bleaches and/ or iodine should not be used, but if they are – if they must be – that thorough rinsing of all metal parts be accomplished. Never should bleach or iodine be allowed to “soak” on the surface of stainless steel without the solution being immediately washed completely off.

Initial evidence of excessive bleach and/or iodine use or lack of thorough rinsing will be a dulling appearance.

Continued use of such practices will result in pin holes in the stainless steel tank and leaking.

## STORAGE

### 1. Storing the Little Therm

- See Cleaning and Sterilizing
- Place the Little Therm upright in a dry area away from any chemicals.

### 2. Storing the Thermal Packs

- Scrub your Thermal Packs with warm soap and water.
- Moist and Cold
  - 1 - Put the moist Thermal Pack in a plastic bag.
  - 2 - Seal the bag.
  - 3- Store the bag in the freezer (recommended) or refrigerator.
- Dry
  - 1- Air dry the Thermal Pack completely in a well ventilated area. The filler will become hard and caked. This doesn't hurt the bags; more Pre-Soaking time is then necessary.
  - 2 - Store in a dry area away from any chemicals.



**TROUBLESHOOTING**

<b>Problem</b>	<b>Cause</b>	<b>Solution</b>
Water doesn't get hot, even though unit is plugged in and switch is ON	Circuit breaker is off Thermostat is not working Heating element is burned out	Adjust the thermostat Replace the thermostat Replace the heating element
Water is cloudy	The Thermo Packs are worn out (seeping) Too long between cleaning	Replace the Thermal Packs Drain, clean and refill
Thermal Packs too hot	The thermostat is set too high The thermostat is broken	Adjust the thermostat Replace the thermostat
Thermal Packs too hot and then too cool	The thermostat is broken	Replace the thermostat
Thermal Packs too cool	The thermostat is set too low The thermostat is broken There is a power failure	Adjust the thermostat Replace the thermostat Check the circuit and turn on the breaker
Rust in unit	Contact with ferrous metal	Remove the ferrous metal item from the unit -usually a staple, paper clip, safety pin, etc. Clean thoroughly.

**REPAIR OF UNIT**

It may be necessary or you may desire to return the Little Therm unit for service. In that case, we would appreciate you contacting Whitehall Manufacturing directly. We will make arrangements for the unit to be returned to our production location. When the unit is received by us, an estimate of repairs will be made and you will be contacted. **Please- we appreciate warranty repair or any other repair be arranged directly with Whitehall Manufacturing. If you are not satisfied with our service, then and only then, contact your dealer.**

# Instructions for Operation and Care of Little Therm Compact Thermalator

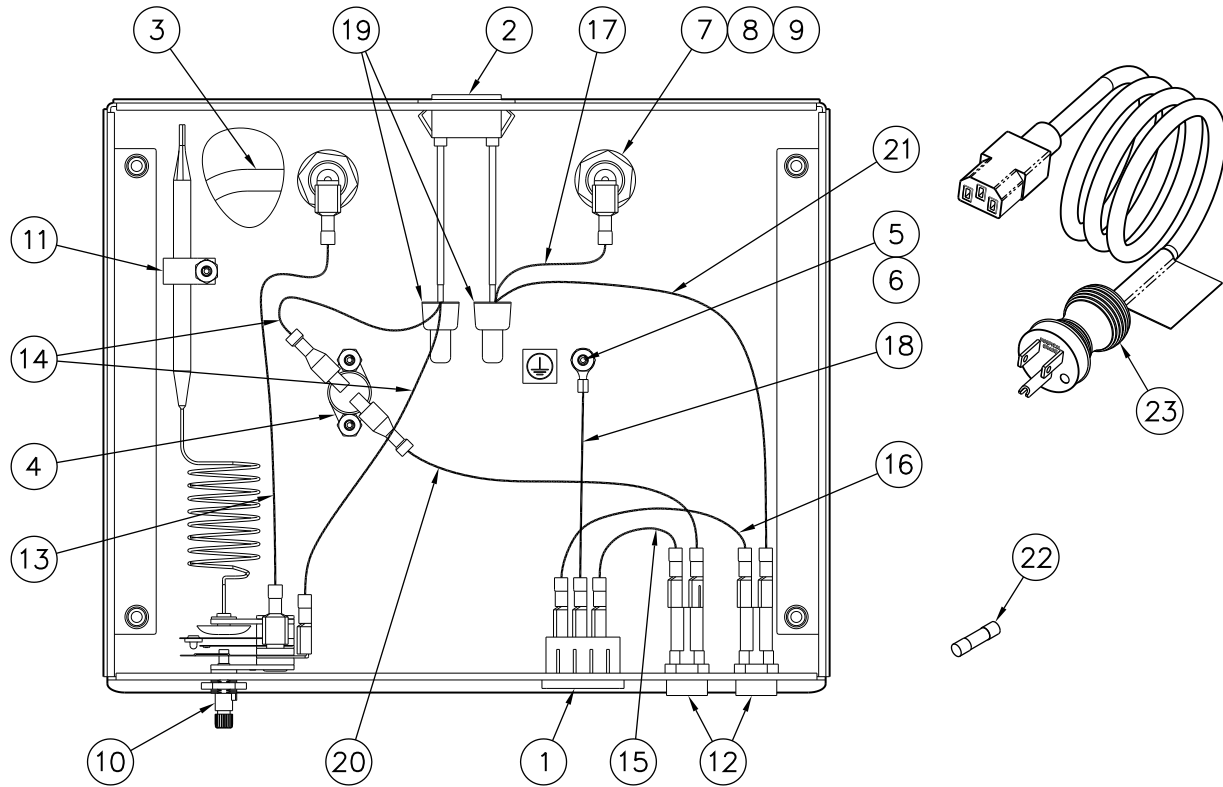

Whitehall Part #	Description
1	6505-546-000 10A/15A 250VAC C14 Snap-In Power Outlet
2	6900-135-000 Neon Indicator Light (Green), 125 VAC
3	6505-500-000 1000W 120V Tubular Heating Element
4	0710-450-000 1/2" Disc Thermostat, Auto Reset
5	0302-011-000 #6-32 UNC Stainless Steel Hex Nut
6	0322-003-000 #6 Plated Star Lock Washer (External)
7	0335-010-000 .515 ID x .815 OD x .064 Thick Brass Washer
8	0440-000-000 .515 ID x .875 OD x .064 Thick SBR Washer
9	0312-008-000 1/2-20 Jam Nut, Brass
10	6903-150-000 Operating Thermostat- Formasplint
11	6900-102-000 Clamp- Steel Cable
12	0710-230-001 Fuse Holder Assembly
13	6704-075-001 Wire Connector Assembly, Brown
14	5904-064-001 Wire Connector Assembly, Brown
15	6704-088-001 Wire Connector Assembly, Brown
16	5904-061-001 Wire Connector Assembly, Blue
17	5904-060-001 Wire Connector Assembly, Blue
18	6704-086-001 Ground Wire Connector Assembly, Green/Yellow
19	0710-108-000 Insulated Crimp Wire Connector
20	6704-077-001 Wire Connector Assembly, Brown
21	5904-065-001 Wire Connector Assembly, Blue
22	0710-216-000 Fuse, 10 Amp, 5mm
23	6505-056-000 Power Cord, 13A, 125V



# Instructions for Operation and Care of Little Therm Compact Thermalator

## WIRING DIAGRAM

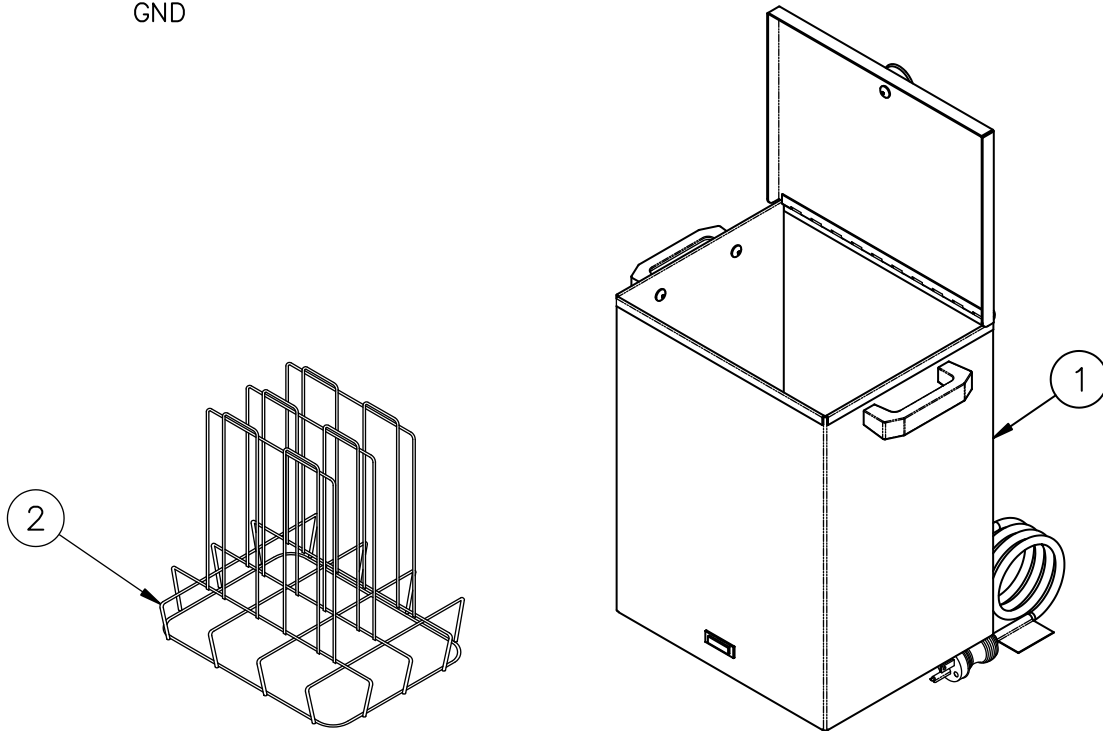
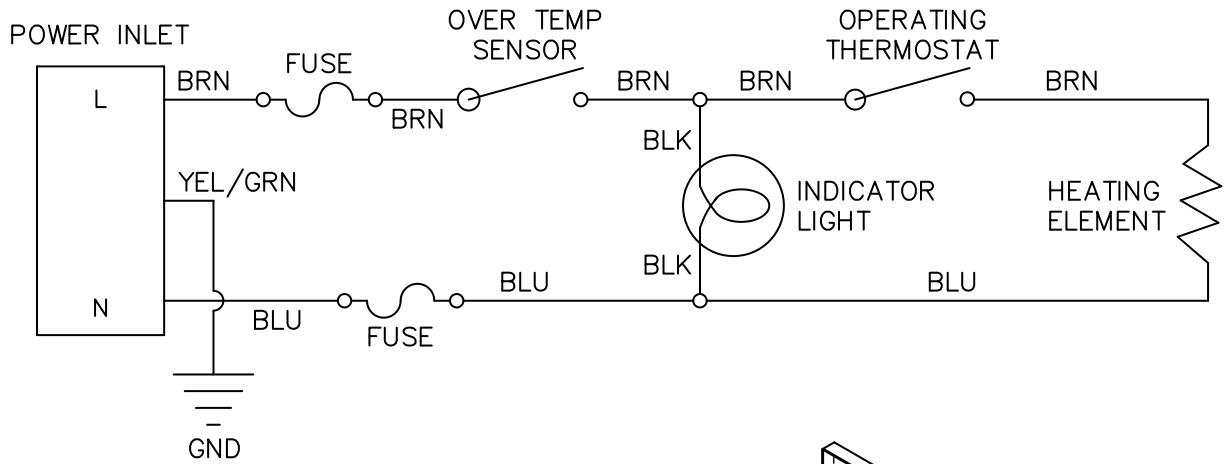

Whitehall Part #	Description
1	6750-002-001 Thermalator Assembly (LT-4)
2	6702-040-199 Vinyl Coated Insert Rack



**Mailing Address:**

P.O. Box 3527 • City of Industry, CA 91744-0527 U.S.A

**Physical Address:**

15125 Proctor Avenue • City of Industry, CA 91746 U.S.A

Phone 800-782-7706 • 626-968-6681

Fax 626-855-4862

Web: [www.whitehallmfg.com](http://www.whitehallmfg.com)

E-mail: [info@whitehallmfg.com](mailto:info@whitehallmfg.com)

Any questions regarding servicing of products in Europe or the Middle East should be directed to:  
Niva Medical Company • Olarinluoma 14 B, FIN-02200 Espoo, Finland  
Phone 358 9 615 00 540 • Fax 358 9 615 00 545  
Web [www.nivamedical.fi](http://www.nivamedical.fi) • E-mail [info@nivamedical.fi](mailto:info@nivamedical.fi)

## MANUFACTURER'S WARRANTY

Whitehall Manufacturing Company warrants that its products are free from defects in material or workmanship under normal use and service for a period of one year from date of shipment. Whitehall's liability under this warranty shall be discharged solely by replacement or repair of defective material, provided Whitehall is notified in writing within one year from date of shipment, F.O.B. Industry, California.

**This warranty does not cover installation or labor charges, and does not apply to materials which have been damaged by other causes such as mishandling or improper care or abnormal use.** The repair or replacement of the defective materials shall constitute the sole remedy of the Buyer and the sole remedy of Whitehall under this warranty. Whitehall shall not be liable under any circumstances for incidental, consequential or direct charges caused by defects in the materials, or any delay in the repair or replacement thereof. This warranty is in lieu of all other warranties expressed or implied. Product maintenance instructions are issued with each fixture, and disregard or non-compliance with these instructions will constitute an abnormal use condition and void the warranty. Stainless steel must be protected on jobsites during construction and must be properly maintained after the water has been introduced into the fixture, or Whitehall's limited warranty is void. If you have any questions or require technical assistance, please call 800-743-8219.

**NOTICE TO KEEP ORIGINAL PACKAGING-** Regarding warranty claims: customer must retain original packaging for one year upon receipt of product. If packaging is discarded, it is the customer's responsibility to provide adequate packaging. Any shipping claims that are a direct result of customer-provided packaging materials will be handled by the shipper.