



LIVING EARTH  
CRAFTS®

# Owner's Manual

## The Designer™ Trolley



## Introduction

Congratulations on the purchase of your Designer™ Trolley by Living Earth Crafts. Please read this Owner's Manual in its entirety and keep it on hand as a reference. Before using this product, please read the following sections carefully:

### Using the Designer™ Trolley Safely

- Safety Information
- Notices and Symbols

These sections provide important information regarding your safety. Should you have any questions or require additional information, we encourage you to contact our office at the information provided below.

### Living Earth Crafts

3210 Executive Ridge Drive  
Vista, CA. 92081

800.358.8292  
760.597.2155

[www.livingearthcrafts.com](http://www.livingearthcrafts.com)

## Intended Use

The Designer™ Trolley is designed to provide discrete storage and convenient access for both a hot stone warmer and a hot towel cabinet. It is intended for use in a variety of treatment rooms and its size and functional design aid the service provider in his or her storage needs. Its built-in electrical outlet strip allows for convenient use and easy transport. With an eye toward both beauty and function, the Designer™ Trolley's stunning top offers a well-sized and sturdy workstation for service providers in need of space.



# CONTENT

<b>INTRODUCTION</b> .....	2
<b>INTENDED USE</b> .....	2
<b>USING THE DESIGNER™ TROLLEY SAFELY</b>	
Notices and Symbols .....	4
Important Warnings .....	4
<b>ELECTRICAL OPERATIONS</b>	
Electrical Specifications .....	5
Plug Description .....	5
Power Outlet Information.....	5
Important Cautions .....	5
<b>INSTRUCTIONS FOR USE</b>	
Accessing the Avonite™ Top .....	6
Installing a Stone Warmer.....	6
Ease of Use .....	6
<b>TROLLEY SPECIFICATIONS</b>	
Overall Dimensions .....	7
Extended Dimensions .....	7
Locking Wheels .....	7
<b>MAINTENANCE, CARE, &amp; TRANSPORTATION</b>	
Maintenance and Care.....	8
Transportation and Storage .....	8
<b>WARRANTY INFORMATION</b>	
Absolute Satisfaction.....	9
Lifetime Limited Warranty.....	9
Contacting Us for Service .....	9

# USING THE DESIGNER™ TROLLEY SAFELY



## SAFETY INFORMATION

INTENDED TO PREVENT FIRE, ELECTRIC SHOCK, AND/OR SERIOUS OR FATAL INJURY TO PERSONS

Safety is always of first concern when using any Living Earth Crafts product. Please read the following safety information carefully. It, along with all of the other information found in the owner's manual, is of the utmost importance.

## NOTICES AND SYMBOLS

About the CAUTION and DANGER notices:

 <b>CAUTION</b>	Intended to alert the user to the risk of serious injury or material damage should the unit be used improperly.
 <b>DANGER</b>	Indicates an imminently hazardous situation which could result in serious or fatal injury. This symbol is used only in the most extreme conditions.

Other symbols:

	Alerts the user to something that must be carried out or completed.
	Alerts the user to something that must never be carried out (is forbidden).
	Fire Hazard
	Keep Dry
	Do not modify
	Electric Shock Hazard

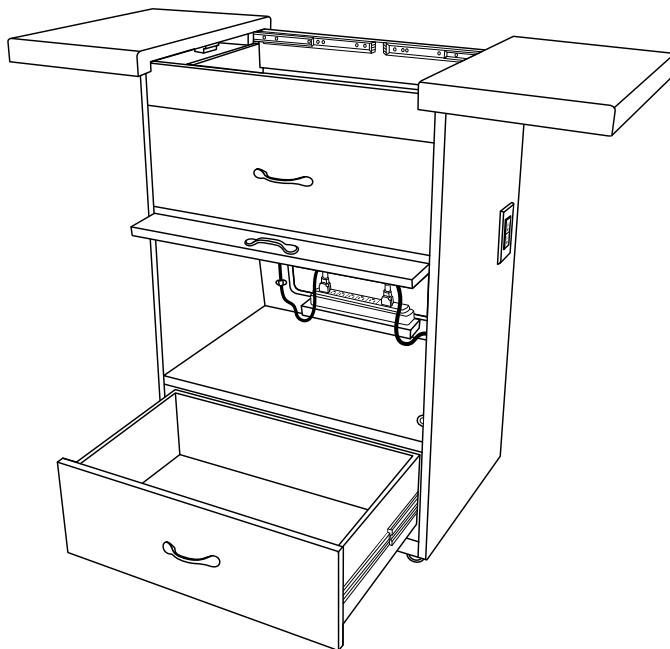

# ELECTRICAL OPERATIONS

## ELECTRICAL SPECIFICATIONS

SERVICE	120V / 60Hz	220V / 50Hz
MAX. AMPERAGE	12A	15A
VOLTAGE	120V AC	220V AC
MAX. CONSUMPTION	1,400 WATTS	3,300 WATTS



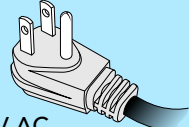
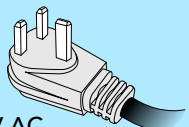



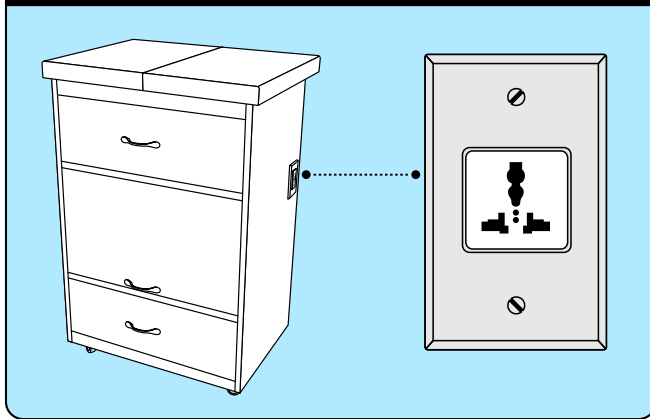

## PLUG DESCRIPTION

North America	Europe / UK
 120V AC	 220V AC













## INTERNATIONAL POWER OUTLET



### CAUTION

-  All cords should be placed so they are out of reach of children.
-  .....
-  Never handle the electrical outlet strip with wet hands. This could result in a potential shock hazard.
-  .....
-  Any accumulation of dust in the electrical outlet strip or in the power outlet can result in poor insulation and lead to fire. Periodically wipe away dust with a dry cloth.
-  .....
-  Before moving the trolley, disconnect all cords connected to or coming from the trolley.
-  .....
-  Before cleaning the trolley, ensure that the electrical outlet strip is unplugged.

### CAUTION

-  Do not twist or bend the power cord, or place heavy objects on it. Doing so can damage the cord. Damaged cords are fire and shock hazards!
-  .....
-  Do not open or modify the electrical outlet strip or power outlet in any way.
-  .....
-  Unplug the trolley and request servicing by Living Earth Crafts if:
  - The electrical outlet strip, power outlet, or power cord has been damaged
  - If smoke or unusual odor occurs
-  .....
-  Use only the electrical outlet strip installed with the trolley. The line voltage at the installation must match the input voltage specified on the electrical outlet strip. Other electrical outlet strips may use different polarities, or be designed for a different voltage, and use of these could result in damage, malfunction, or electric shock.
-  .....
-  Do not force the trolley's power cord to share an outlet with an unreasonable number of other devices. Be especially careful when using extension cords—the total power used by all devices connected to an extension cord's outlet must never exceed the power rating (watts/amperes) for that extension cord. This can cause fire or other harmful situations.
-  .....
-  .....
-  .....



# INSTRUCTIONS FOR USE

## ACCESSING THE AVONITE™ TOP

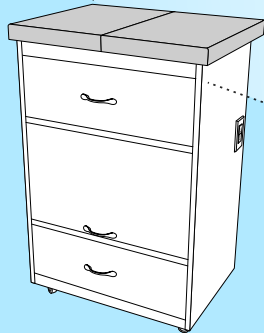

The custom Avonite™ top glides open and closed for easy access to the hot stone warmer.

## INSTALLING A STONE WARMER

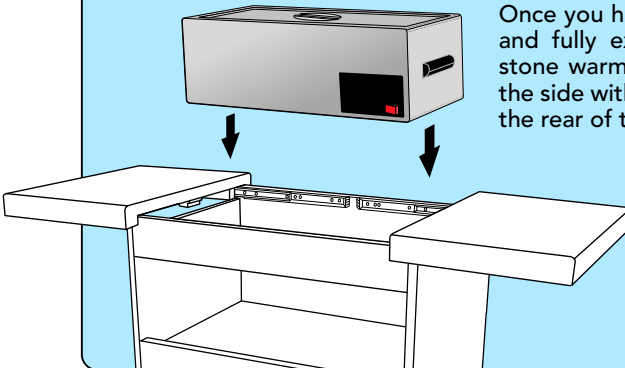

Once you have the trolley top open and fully extended, place the hot stone warmer in the trolley so that the side with the power switch faces the rear of the trolley.



\* Installing the warmer with its power switch facing the front of the trolley will make the switch extremely difficult to access.

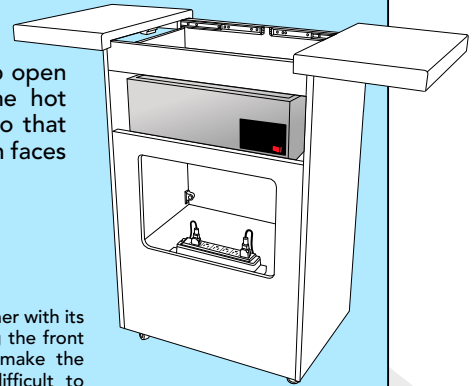

## EASE OF USE

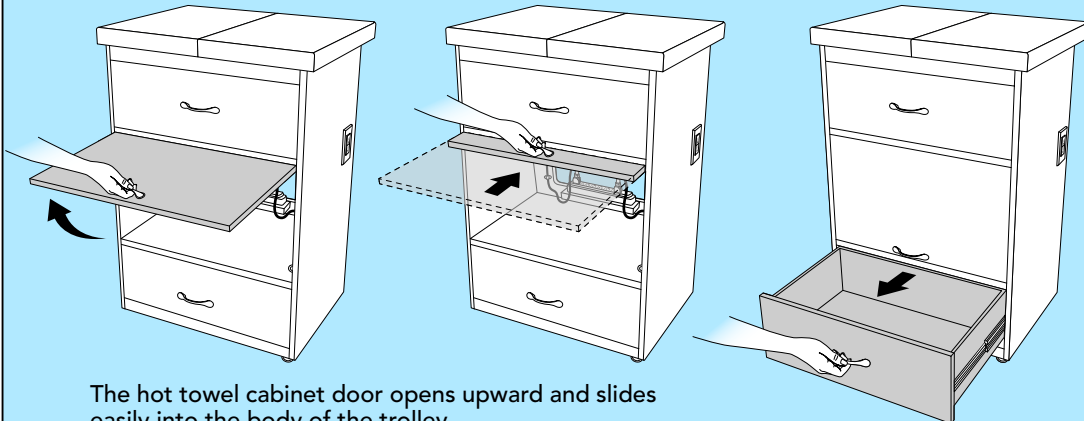

The hot towel cabinet door opens upward and slides easily into the body of the trolley.

The bottom drawer glides open for extra storage.



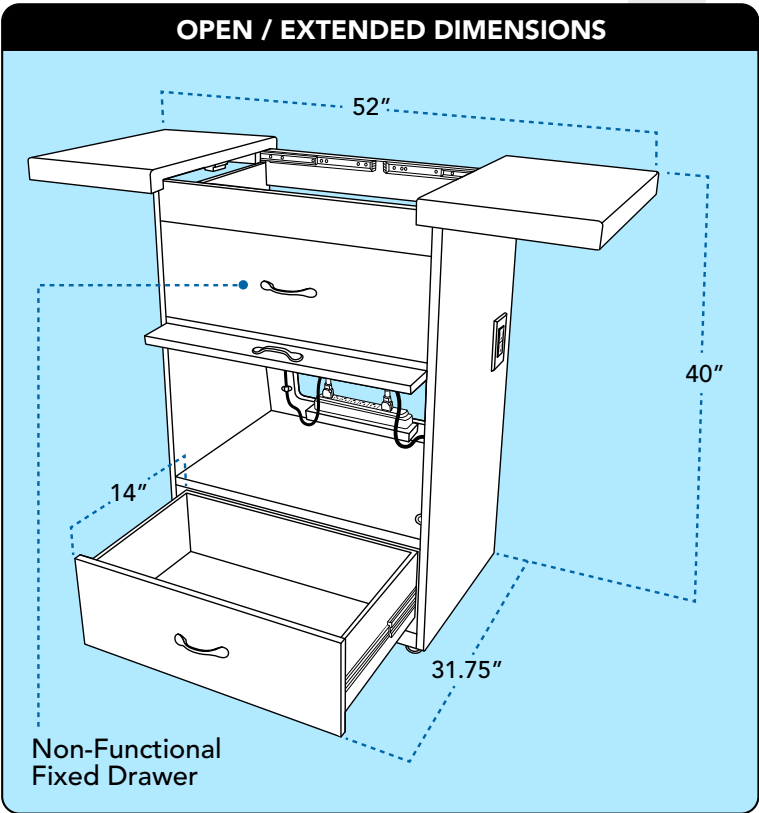
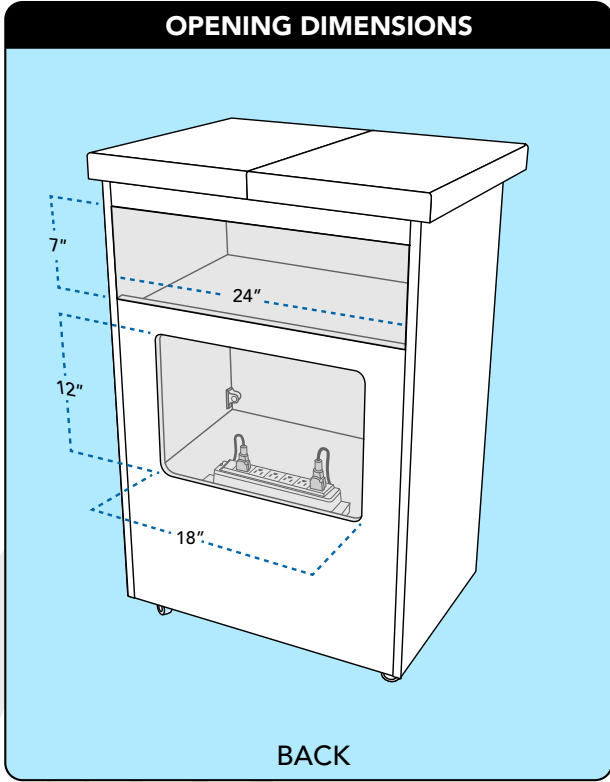
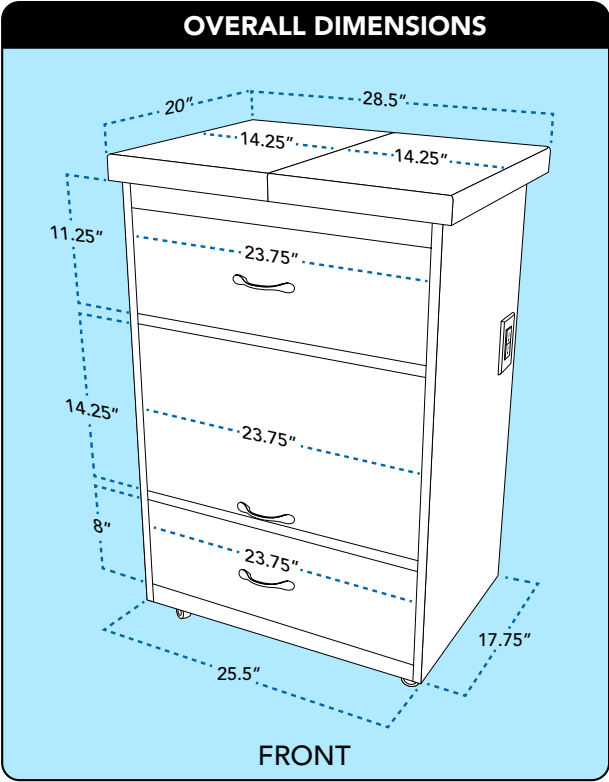

# TROLLEY SPECIFICATIONS

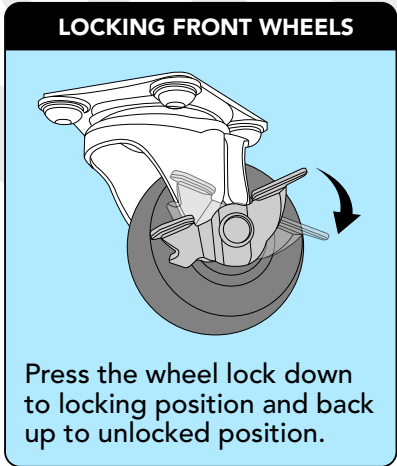

TROLLEY	AVONITE™ TOP
Height: 40"	Height: 2.5"
Width: 25.5"	Width: 28.5"
Depth: 17.75"	Depth: 20"
Weight: 102.25 lbs	







# MAINTENANCE AND CARE

-  Use a mild, diluted non-alcohol cleanser to wipe down the surfaces of the Avonite™ top. To maintain the remaining surfaces of the trolley, use a mild dish soap.  
.....
-  Ensure that excess liquid does not drip onto, or into, any of the electrical controls or outlets.  
.....
-  The trolley should be unplugged from all electrical outlets before cleaning these areas.  
.....
-  Ensure condensation from hot stone warmer or other appliances is wiped away daily to avoid damage of the trolley. Excessive steam and/or water can damage your trolley.  
.....
-  Water spills should be removed immediately from surfaces.  
.....

# TRANSPORTATION AND STORAGE

**Extreme care should be taken when transporting the Designer™ Trolley.**

-  Empty the trolley of any free moving materials prior to transport and/or storage and ensure that all electrical items have been unplugged from the trolley's outlets.  
.....
-  The trolley's electrical outlets should never be in use while in storage as this could pose a potential fire hazard.  

- .....
- The trolley should be stored between 32° and 100°.  
.....
-  Before moving the trolley, disconnect all cords connected to or coming from the trolley.  
.....
- .....
- Ensure the trolley's wheels are locked prior to shipping.  
.....

\* There are no known pressure limitations for the Designer™ Trolley.



## ABSOLUTE SATISFACTION

All Living Earth Crafts products are built with the utmost in care and quality. If you are not completely satisfied with your Living Earth Crafts product and would like to return it, contact your sales representative within 30 days of receipt for a Return Authorization (RA) number. Customers are responsible for return shipping costs and a 20% restocking fee. All returned items must be in new condition, in the original packaging, and with the original receipt. Living Earth Crafts will not accept a returned package that does not have an RA number. Products returned to the factory damaged are the responsibility of the sender. Custom tables and custom accessories do not qualify for our 30-day return policy, but may be otherwise warranted for defects.

## LIFETIME LIMITED WARRANTY

We guarantee the Designer™ Trolley against defects in material and workmanship for one year after purchase. Living Earth Crafts may repair defective components or parts at our discretion. Normal wear and tear, costs associated with maintenance, and damage caused by accident, misuse, improper maintenance, harsh operating environments or neglect are not covered under the warranty. All warranties are limited to repair or replacement, at the company's discretion, unless otherwise stated. Shipping costs inbound or outbound will apply. Contact your representative for additional details.

## CONTACTING US FOR SERVICE

At Living Earth Crafts, we do our utmost to provide clients with the service they need. Should any questions arise as to the maintenance and care of your trolley or should you feel it may require repair under its warranty, we encourage you to contact our office at:

### **Living Earth Crafts**

3210 Executive Ridge Drive  
Vista, CA. 92081

800.358.8292

760.597.2155

**[techsupport@livingearthcrafts.com](mailto:techsupport@livingearthcrafts.com)**



LIVING EARTH  
C R A F T S.

*the choice...  
of world class spas*

